

**Peugeot 3008 Hybrid (2021- )**  
**Opel Grandland X Hybrid (2020- )**  
**Citroën C5 Aircross Hybrid (2020- )**





**R55**

Peugeot 3008 Hybrid (2021-)  
 Opel Grandland X Hybrid (2020-)  
 Citroën C5 Aircross Hybrid (2020-)

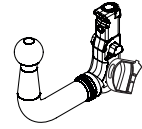
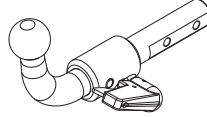
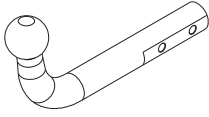

**TowCar** enganches **aragon**

**E<sub>9</sub>** APPROVALNUMBER **55R-01 2479** D-VALUE D **8,5** kN

TYPE **PEU050** CLASS **A50-X** MAX.VERT.LOAD S **103** kg

**TowCar** enganches **aragon**

**E<sub>9</sub>** APPROVALNUMBER **55R-01 2479** D-VALUE D **8,5** kN

TYPE **PEU050** CLASS **A50-X** MAX.VERT.LOAD S **103** kg

**TowCar** enganches **aragon**

**E<sub>9</sub>** APPROVALNUMBER **55R-01 2480** D-VALUE D **8,5** kN

TYPE **PEU051** CLASS **A50-X** MAX.VERT.LOAD S **103** kg

D=8,5 kN



S = 103 kg

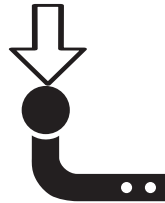

\*T 1350 Kg



N/m	8,8	10,9	12,9
<b>M6</b>	10	15	18
<b>M8</b>	24	36	42
<b>M10</b>	51	75	87
<b>M12</b>	87	130	147
<b>M14</b>	138	198	231
<b>M16</b>	200	289	341

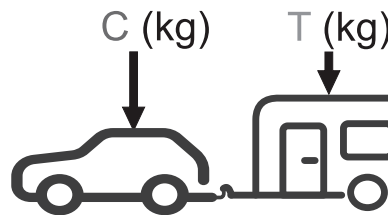

$g = 9,81 \text{ m/s}^2$

$$D \geq \frac{T \cdot C}{T+C} \cdot \frac{g}{1000} \text{ (kN)}$$

$$T \leq \frac{C \cdot D \cdot 1000}{(C \cdot g) - (1000 \cdot D)} \text{ (kg)}$$

\*El MMR (T) puede variar dependiendo del vehículo.

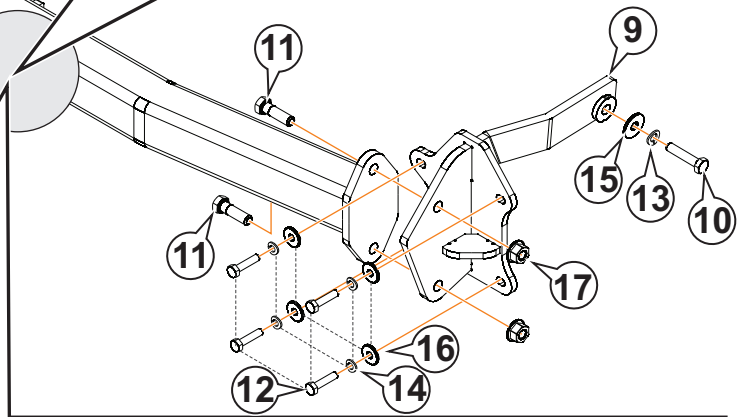
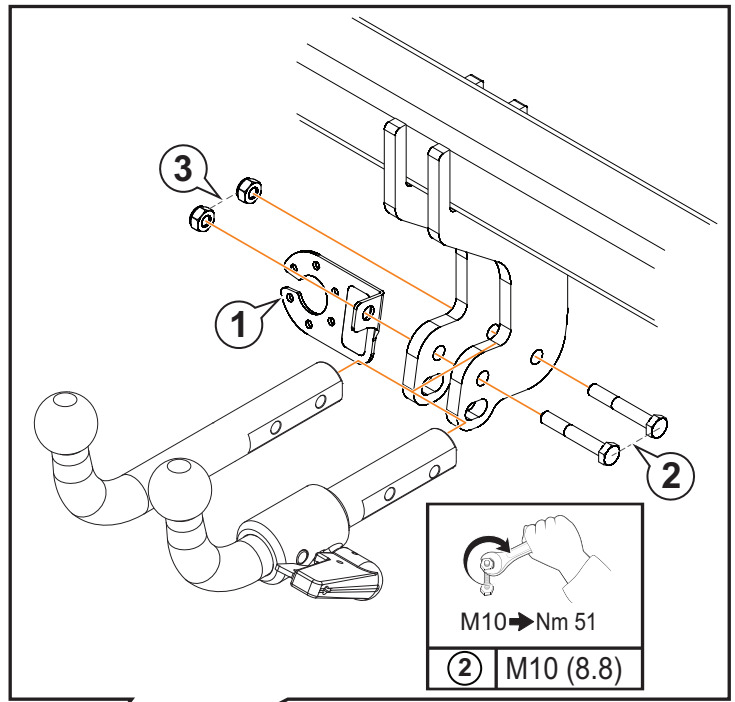
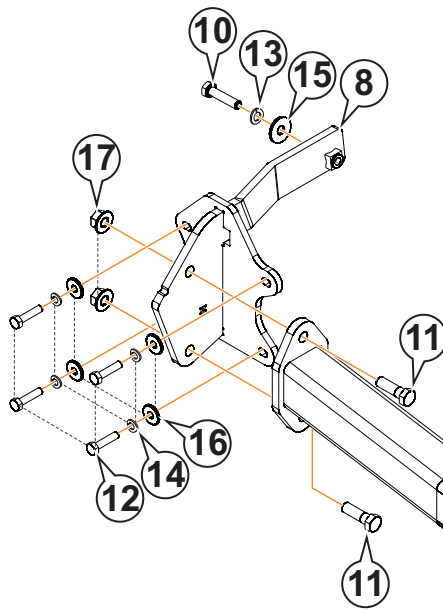

**Opel Grandland X  
Peugeot 3008**

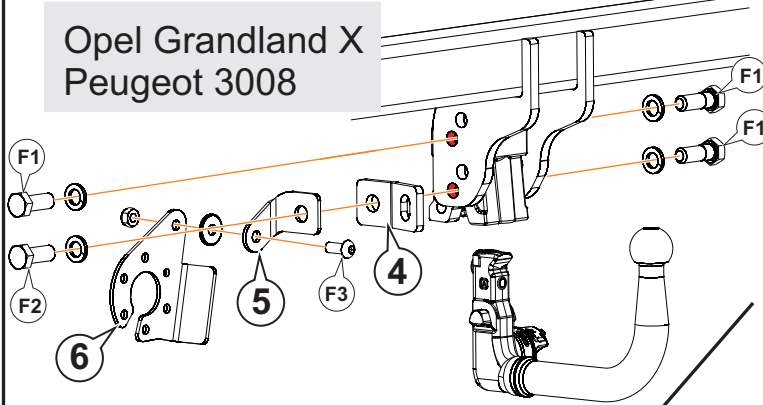







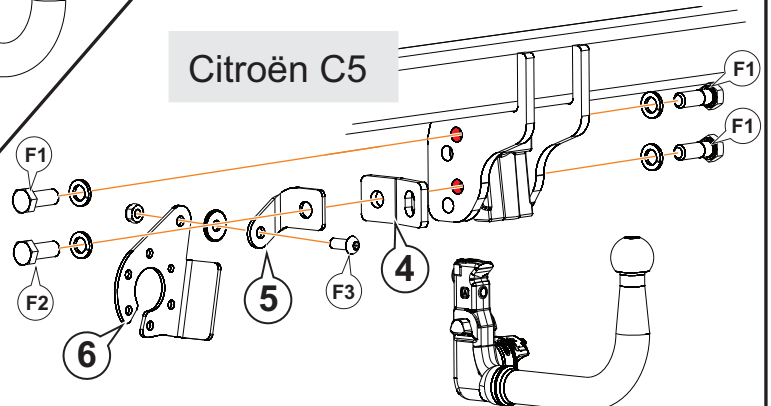

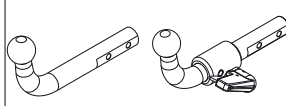
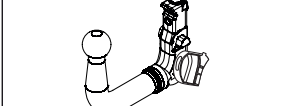









		#
<b>F1</b>	M12 x 25 DIN 933	3
	Ø12 Grower DIN 128	3
<b>F2</b>	M12 x 30 DIN 933	1
	Ø12 Grower DIN 128	1
<b>F3</b>	M8 x 20 DIN 933	1
	Ø8 Poliuretano / Nylon	1
	M8 DIN 980	1

	M12 -> Nm 87
	M10 -> Nm 51
(F1)	M12 (8.8)
(F2)	M12 (8.8)
(F3)	M10 (8.8)

**Citroën C5**



				
1		AEV0005	1	
2		M10x65 DIN 931 (8.8)	2	
3		M10 DIN 980	2	
4		AEV0006		1
5		AEV0038		1
6		AEV0039		1
7		C4723DX60	1	1
8		C4723DA62	1	1
9		C4723DA61	1	1
10		M10x45 DIN 933 (8.8)	2	2
11		M12x40 DIN 933 (8.8)	4	4
12		M8x35 DIN 933 (8.8)	8	8
13		Ø10 DIN 128A	2	2
14		Ø8 DIN 128A	8	8
15		Ø10 DIN 9021	2	2
16		Ø8 DIN 9021	8	8
17		M12 DIN 6923	4	4

1



5 min.

?

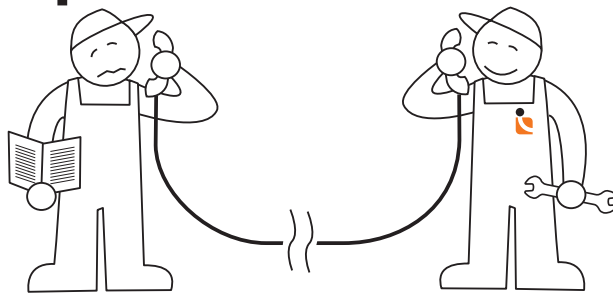

Tel.: (+34) 976 457 130

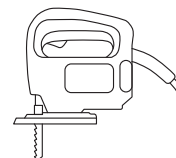
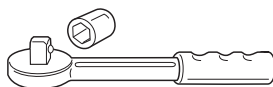
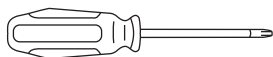

2

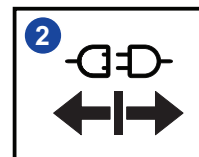
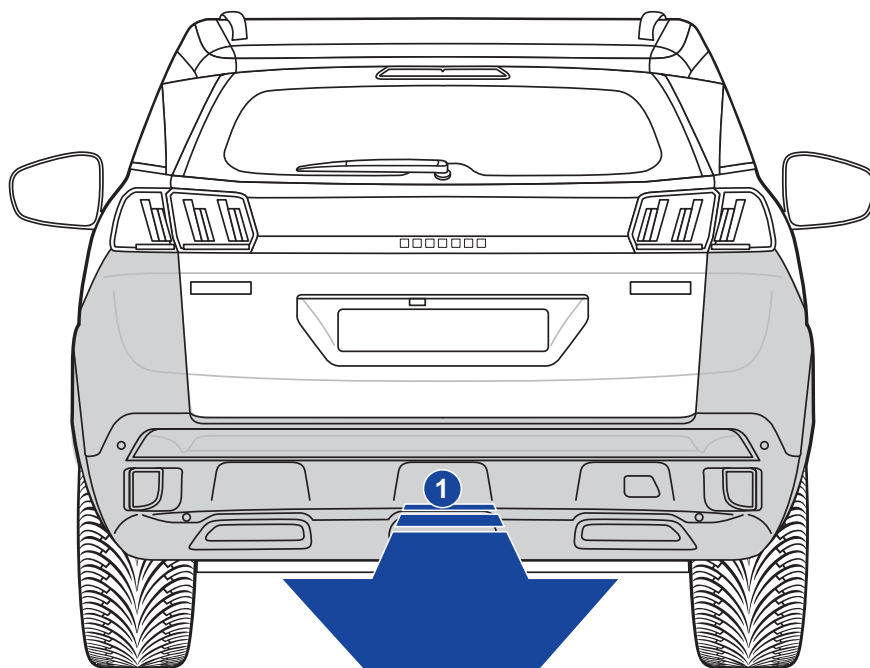

**3**

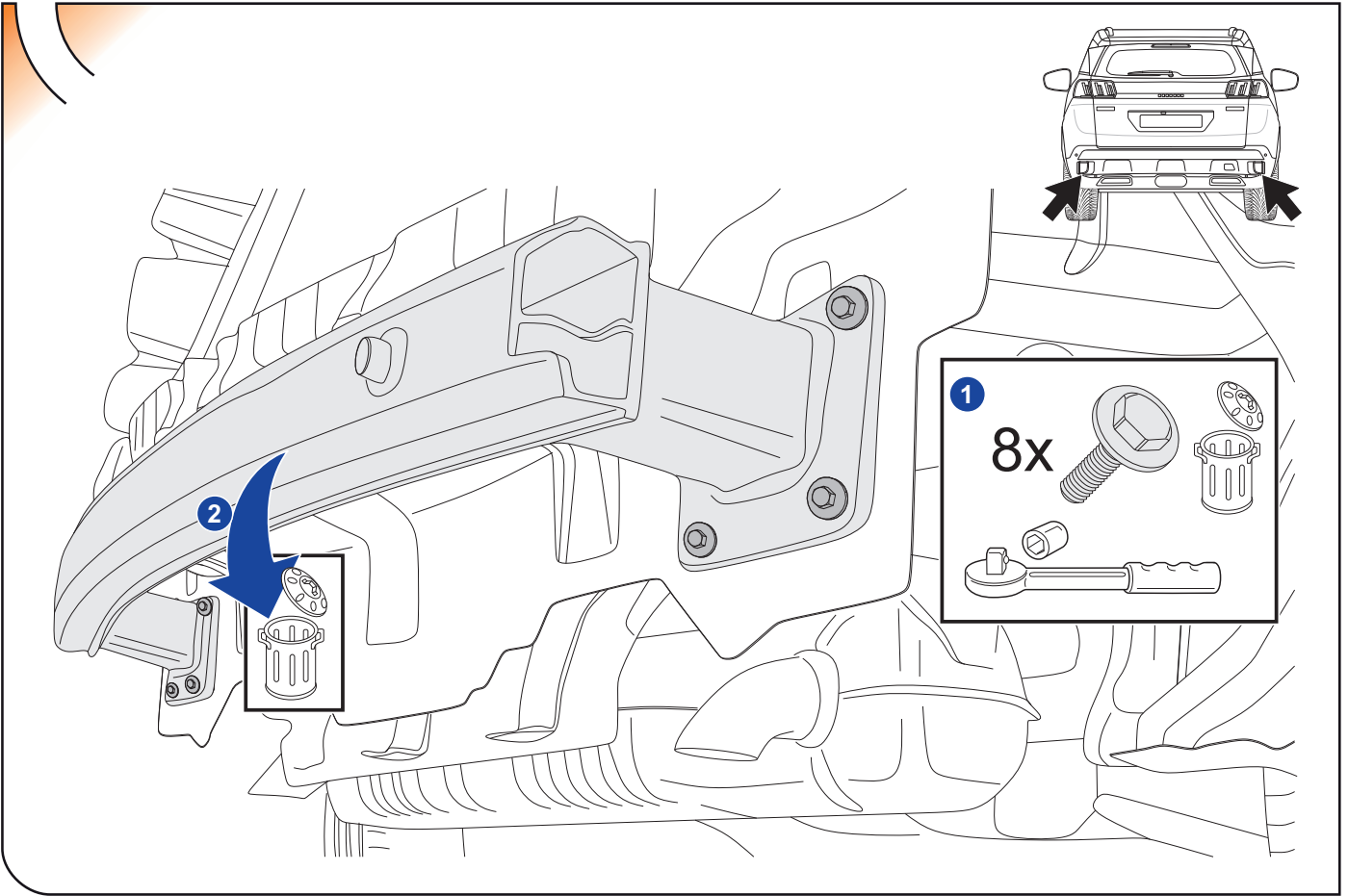

**4**

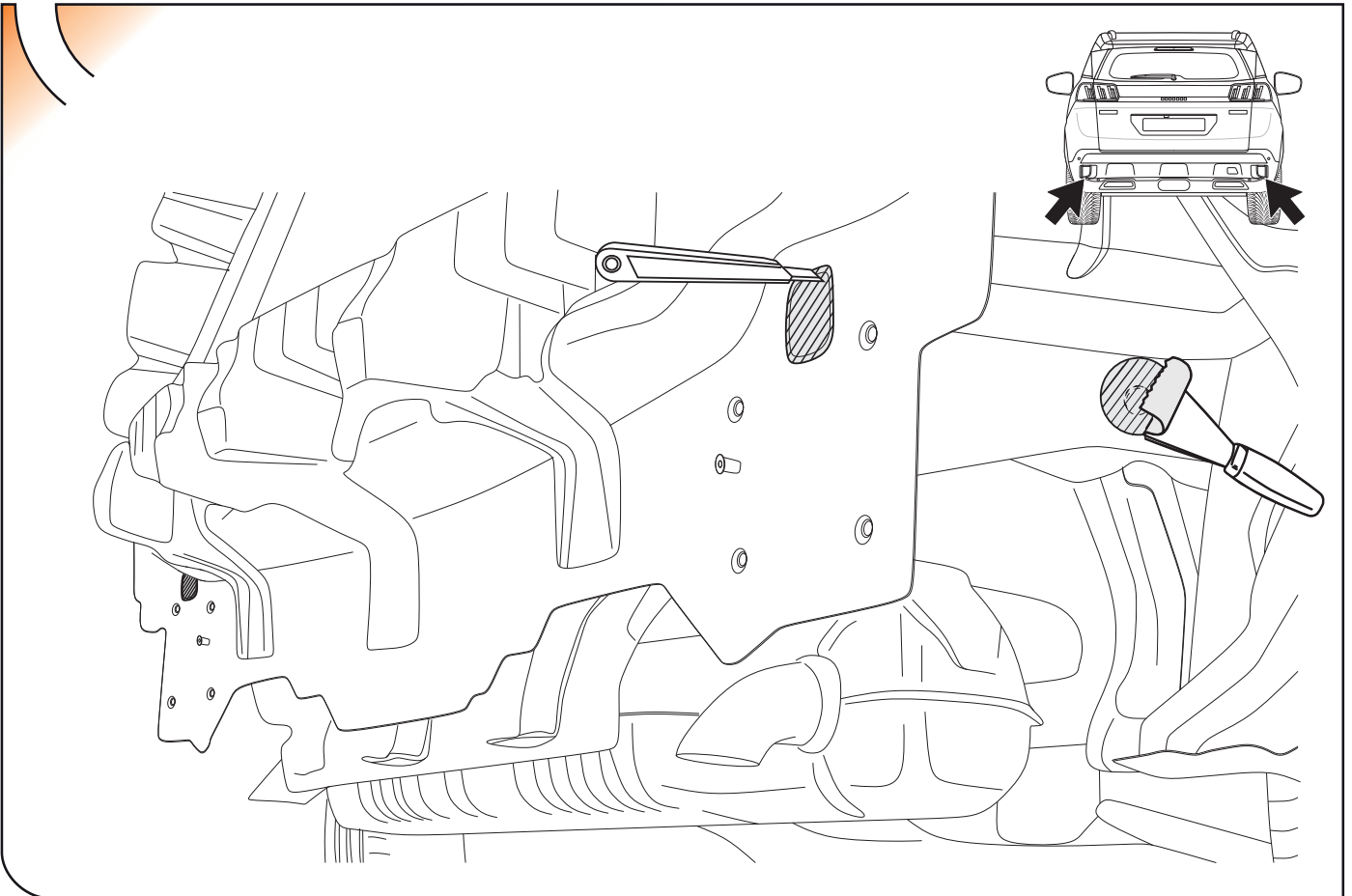

5

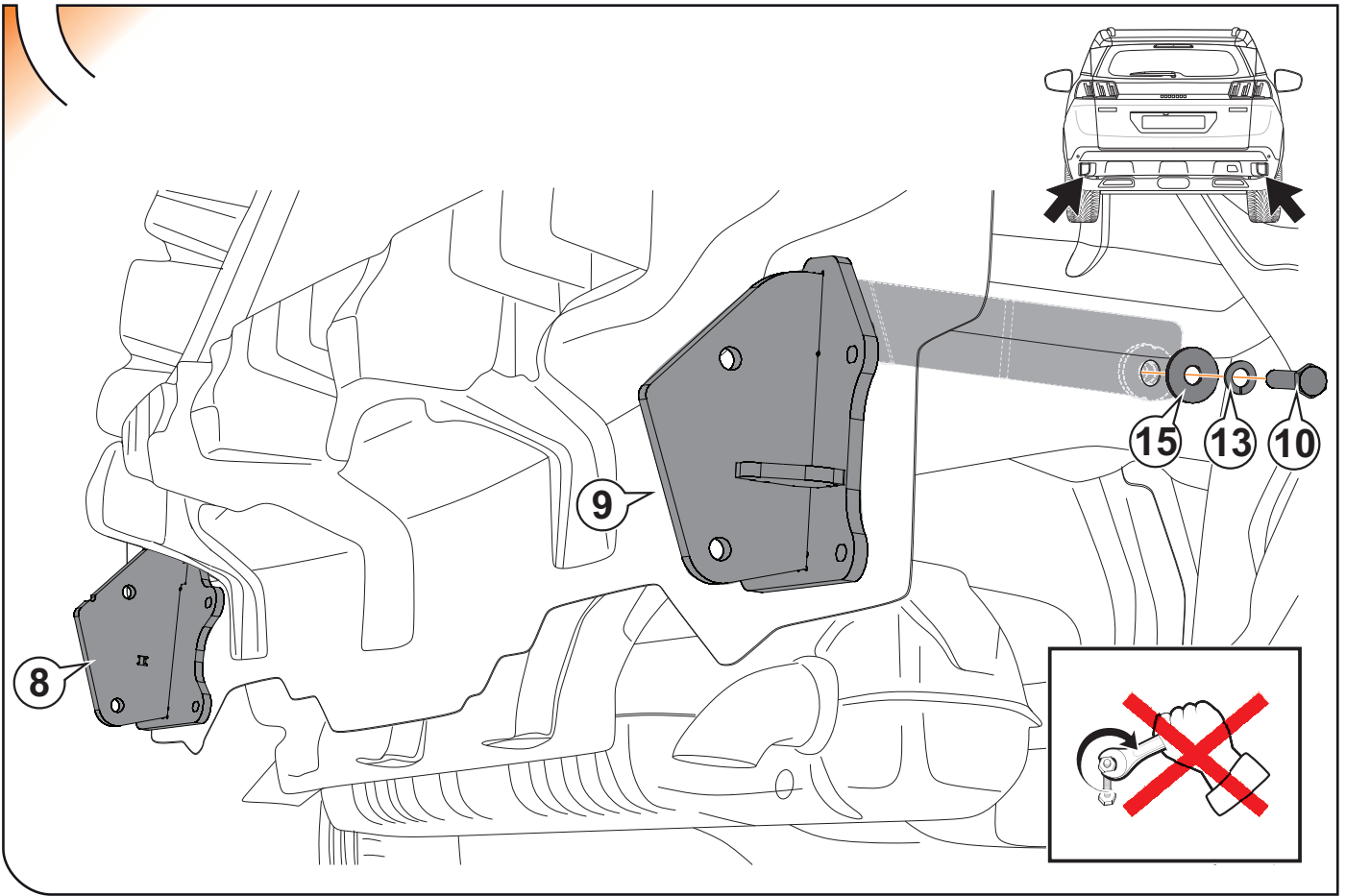

6

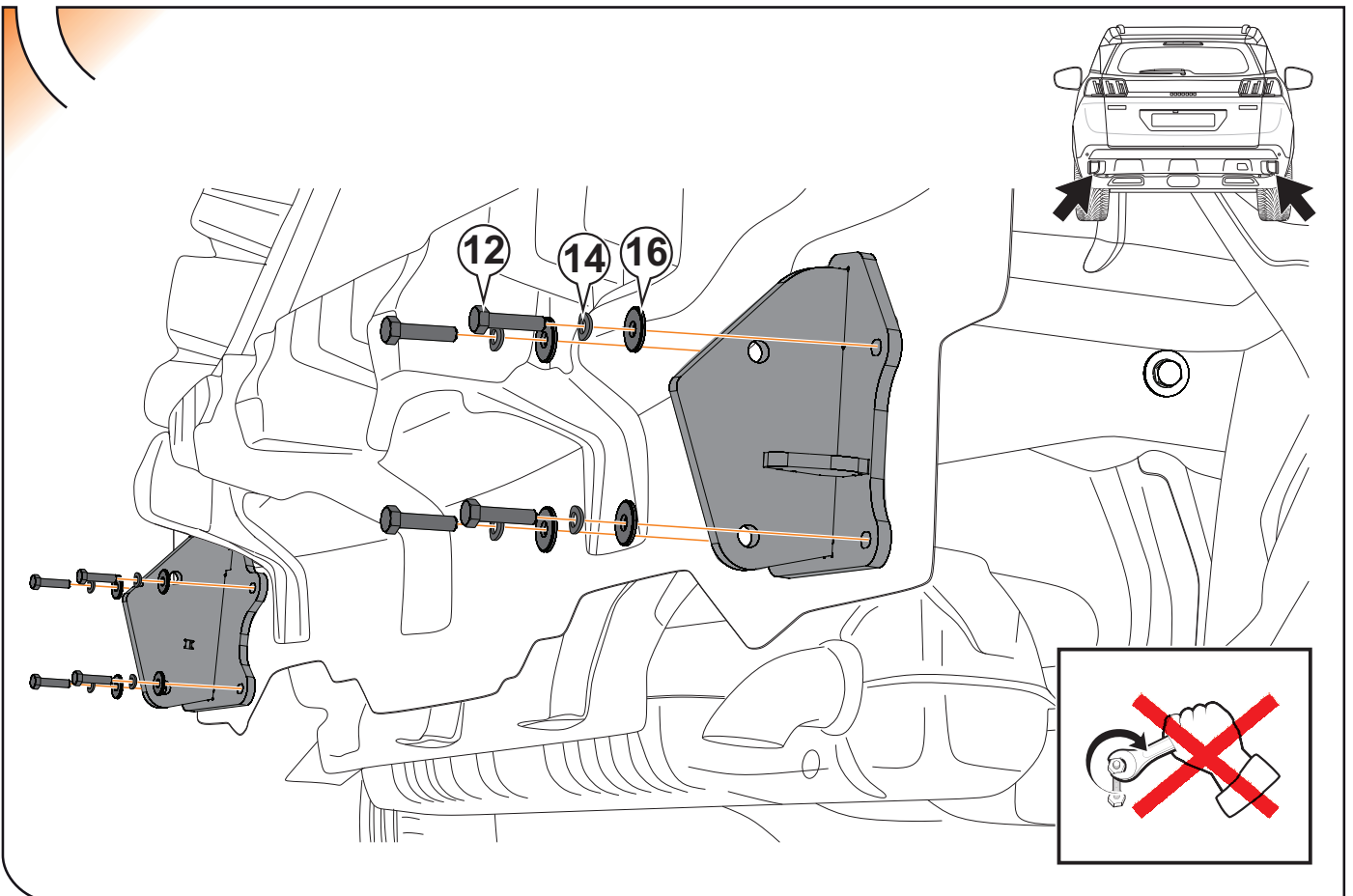



7

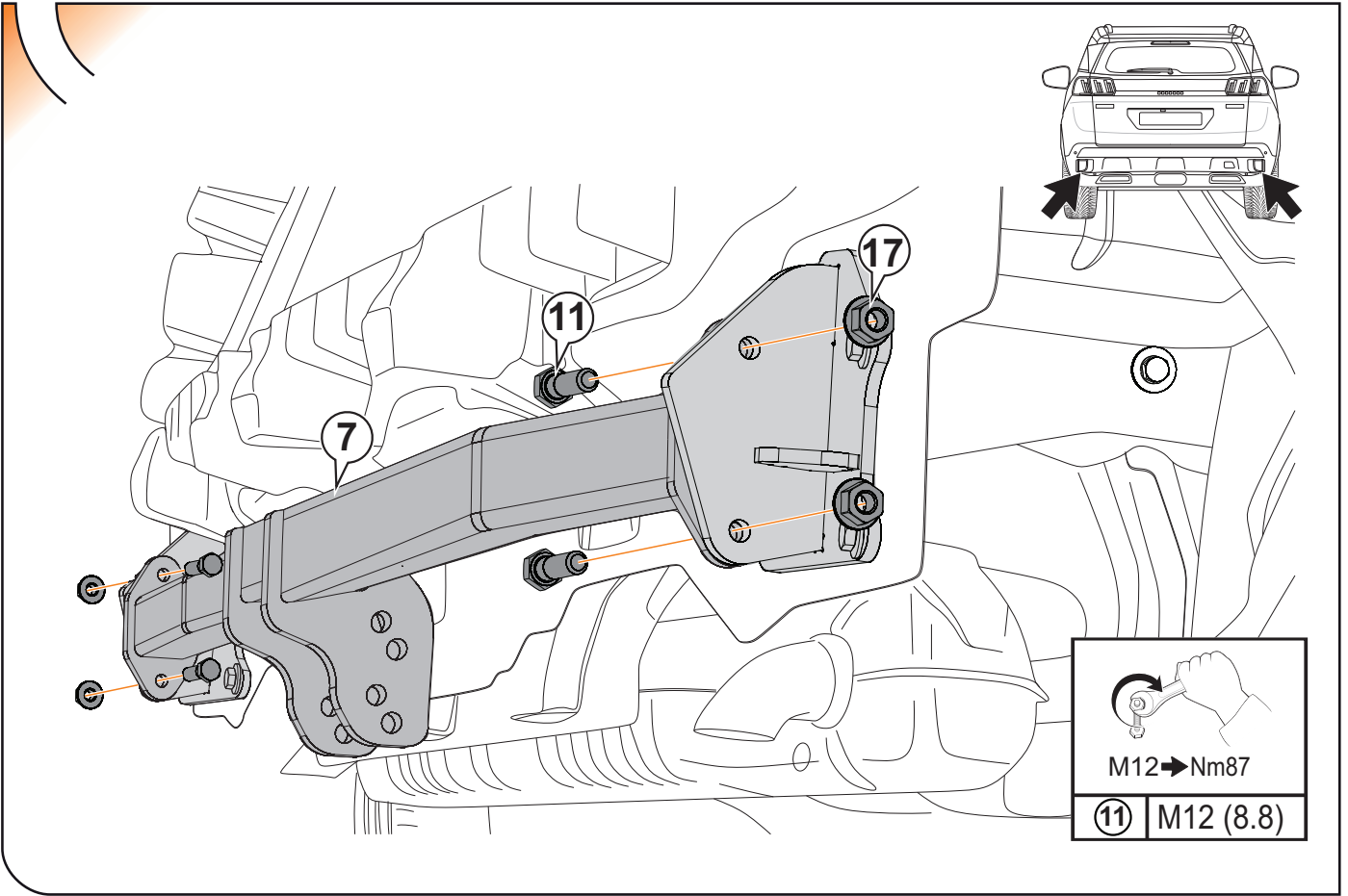

8

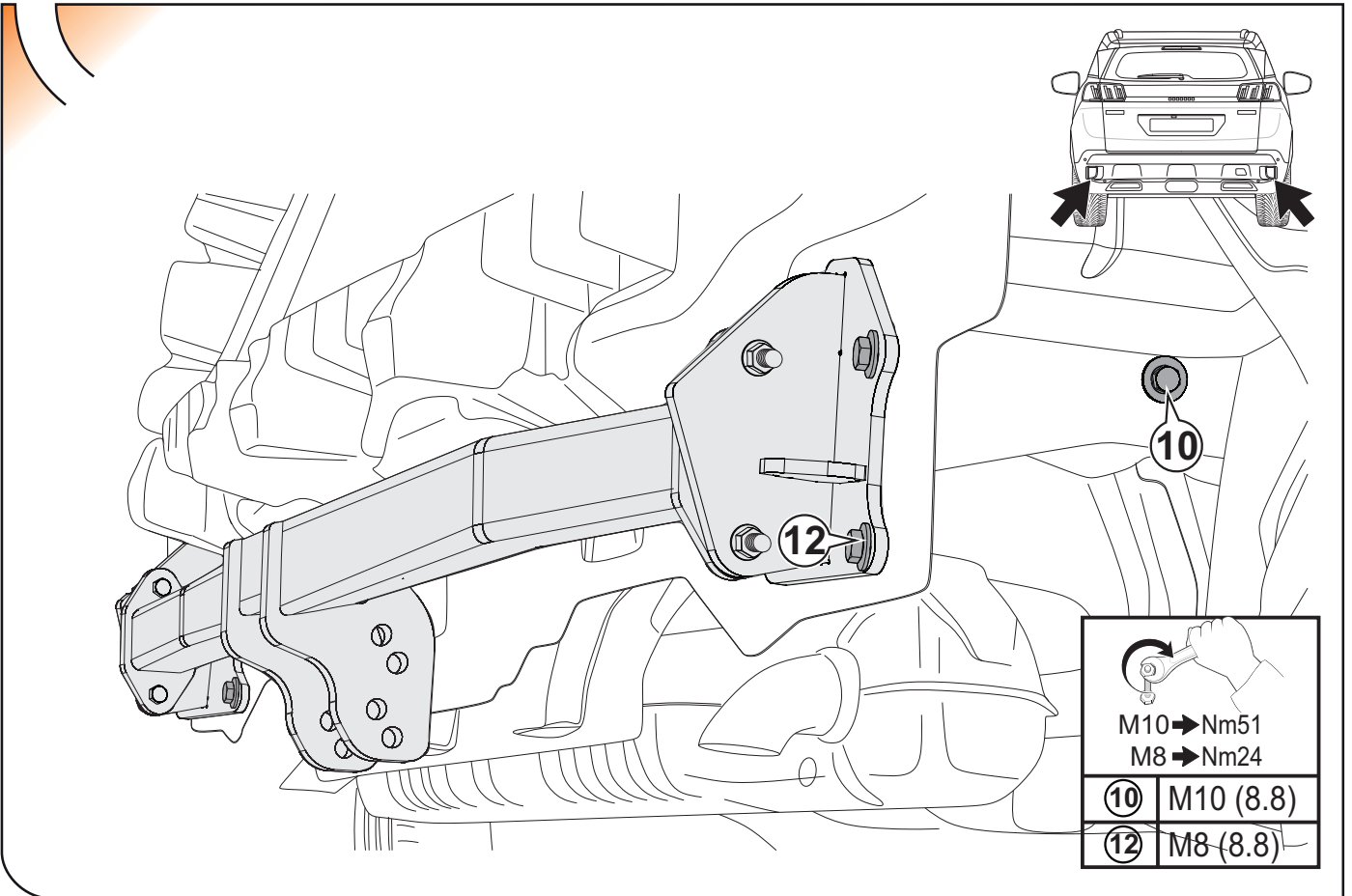

9

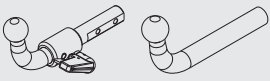

Peugeot 3008

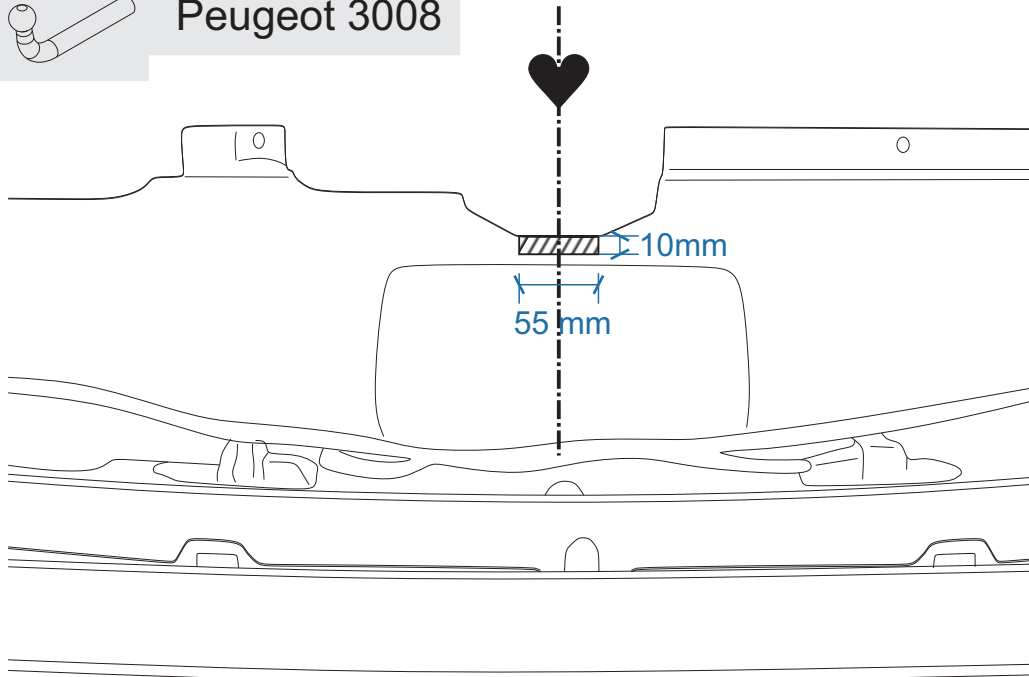

- 1
- 2
- 3

10

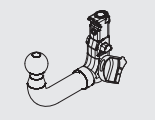

Peugeot 3008

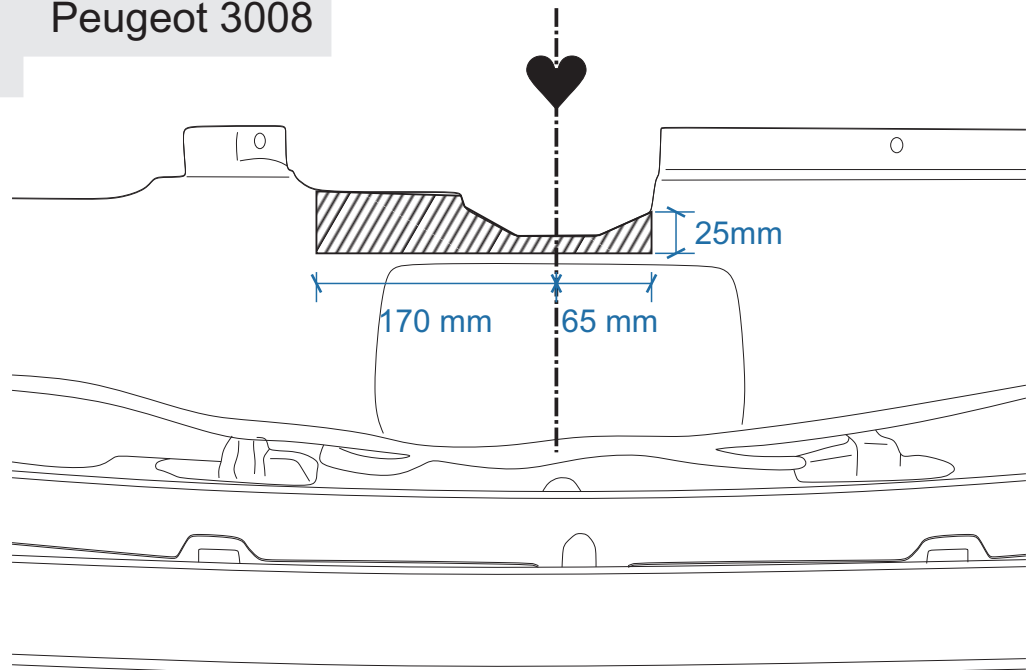

- 1
- 2
- 3

11

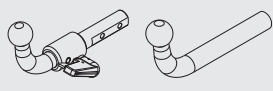

Opel Grandland X

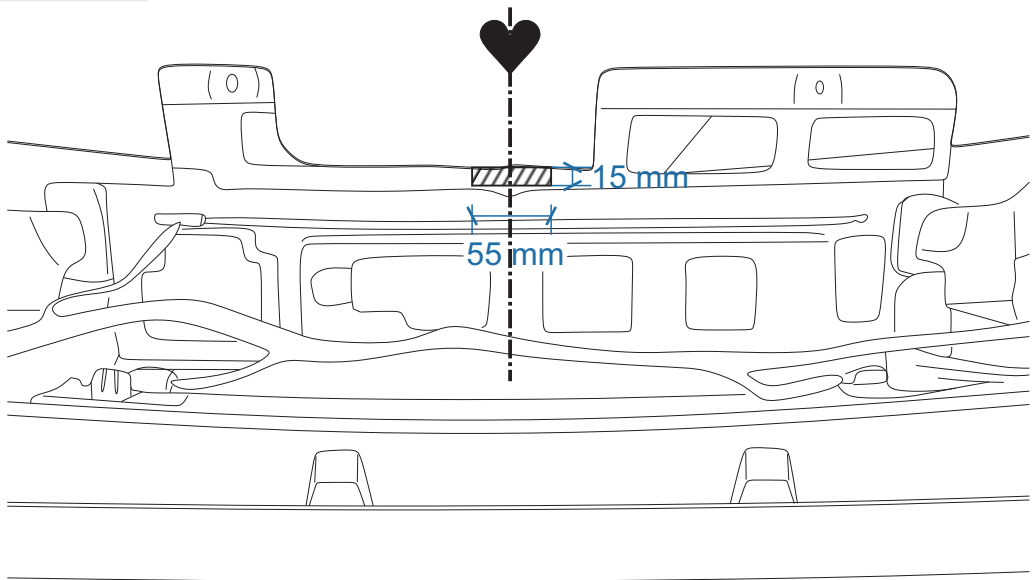

- 1
- 2
- 3

12

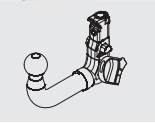

Opel Grandland X

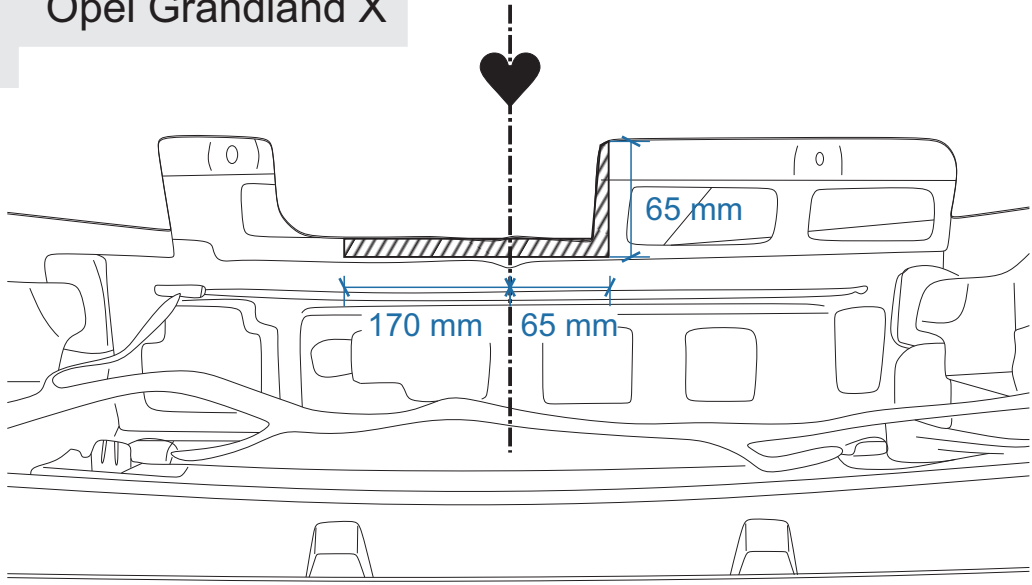

- 1
- 2
- 3

13

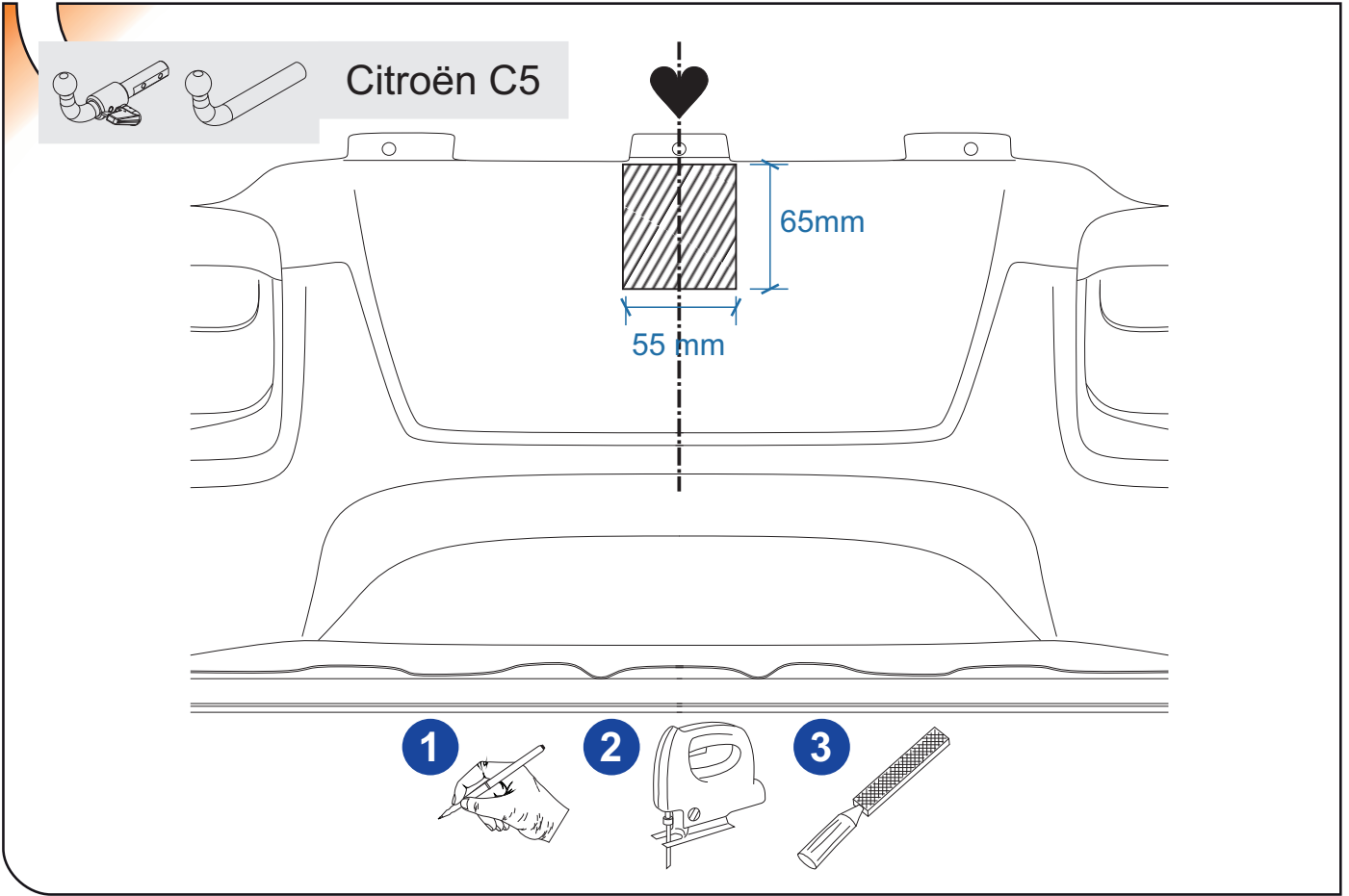

14

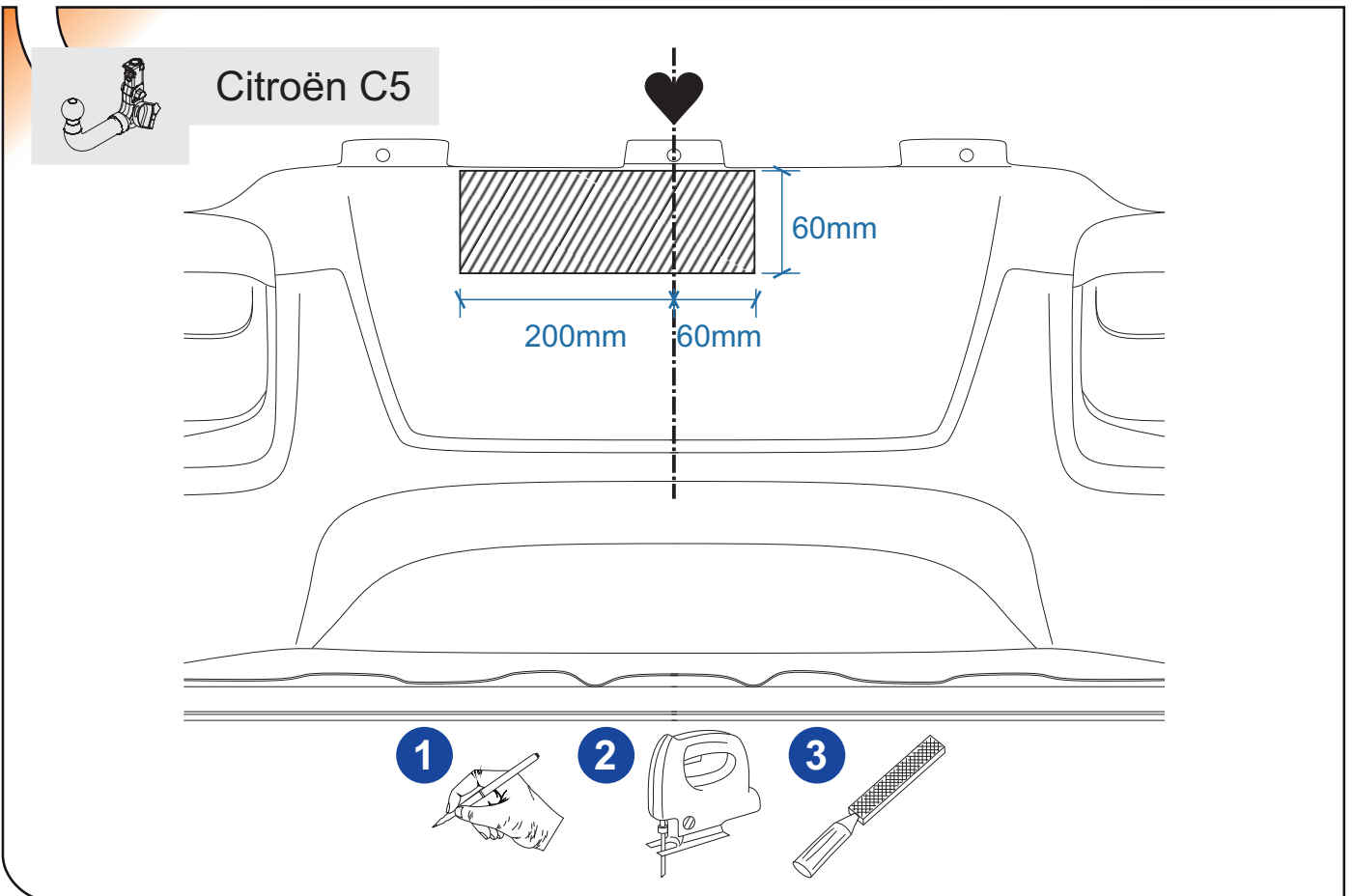

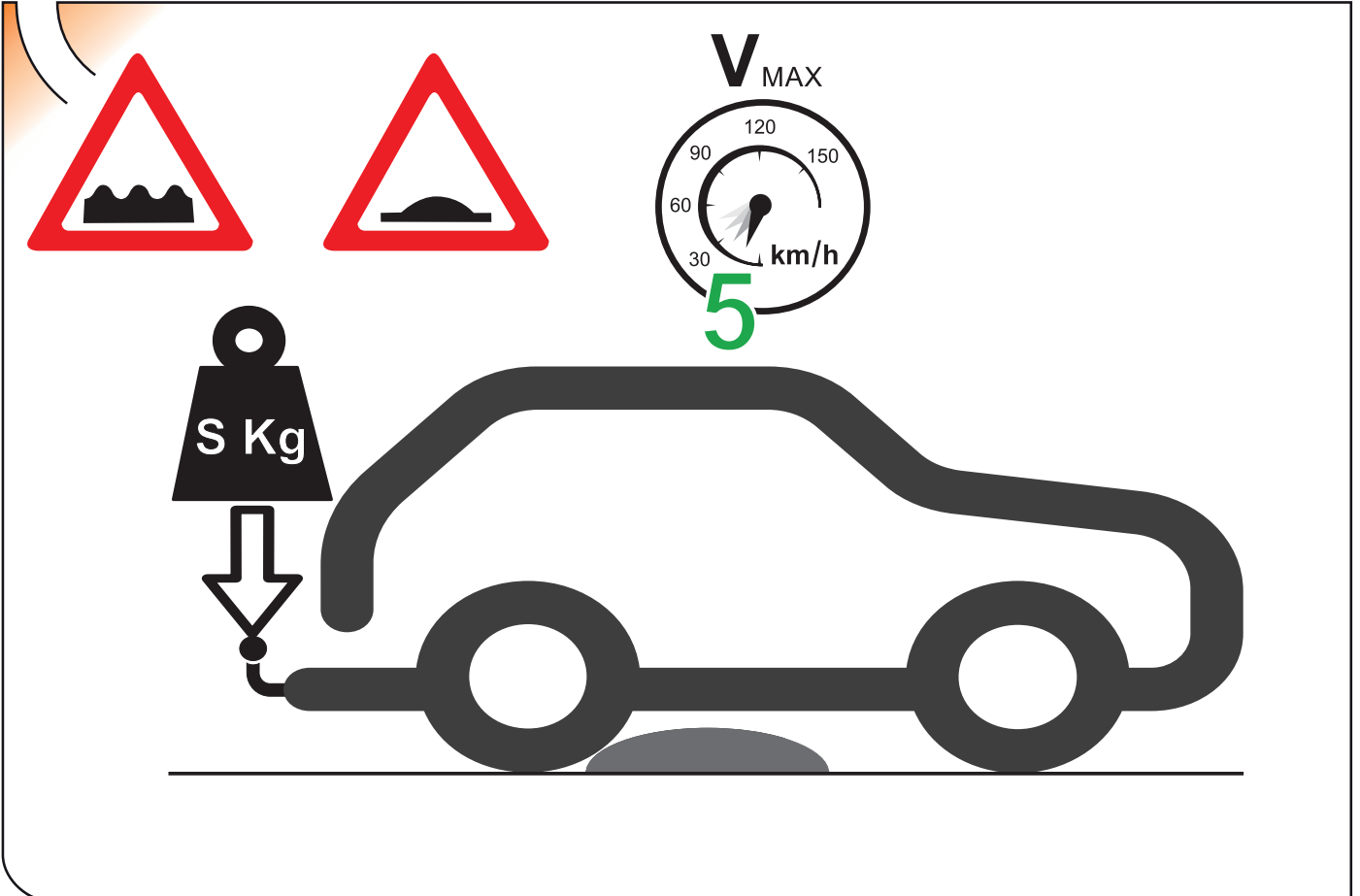
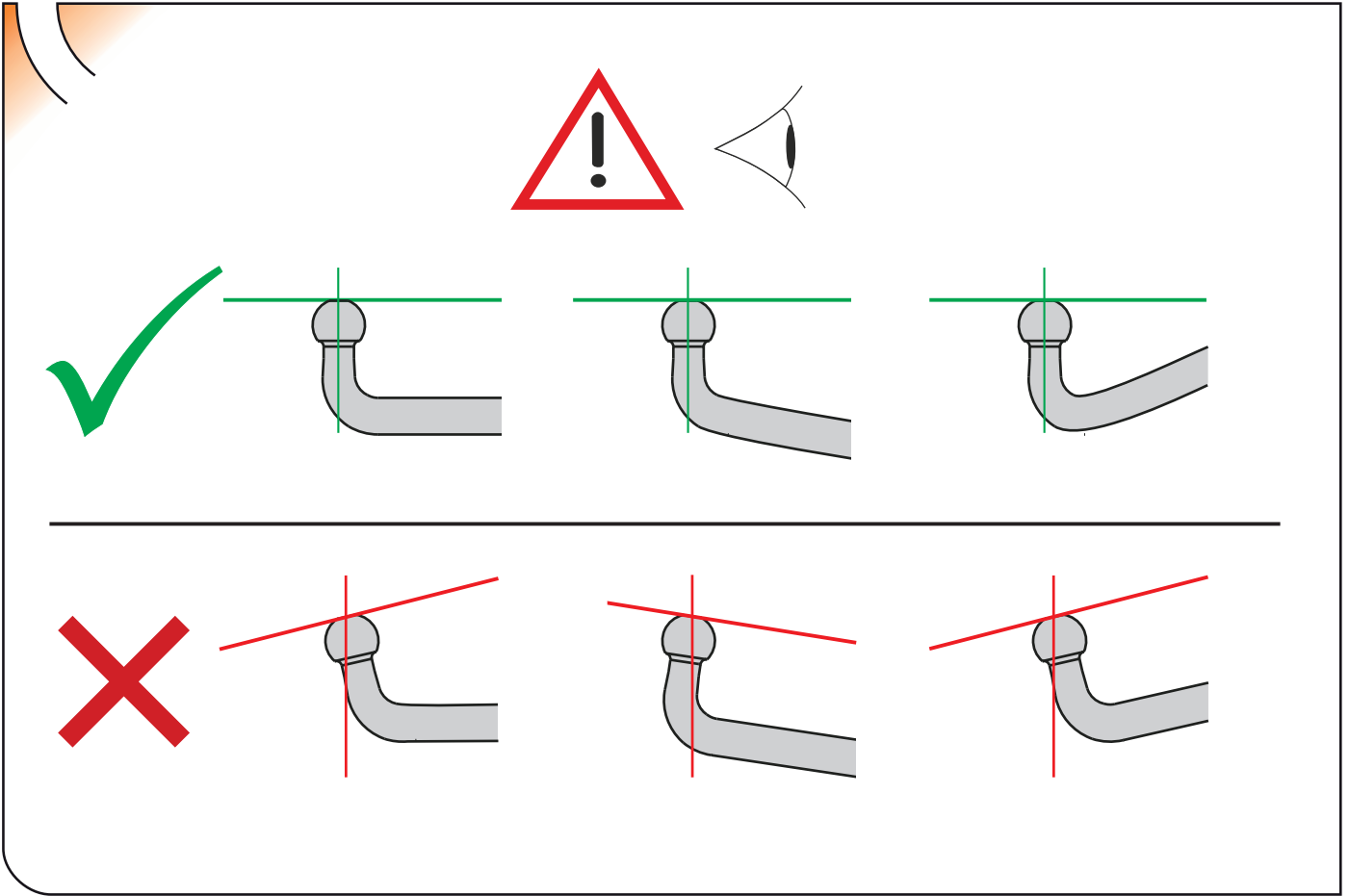

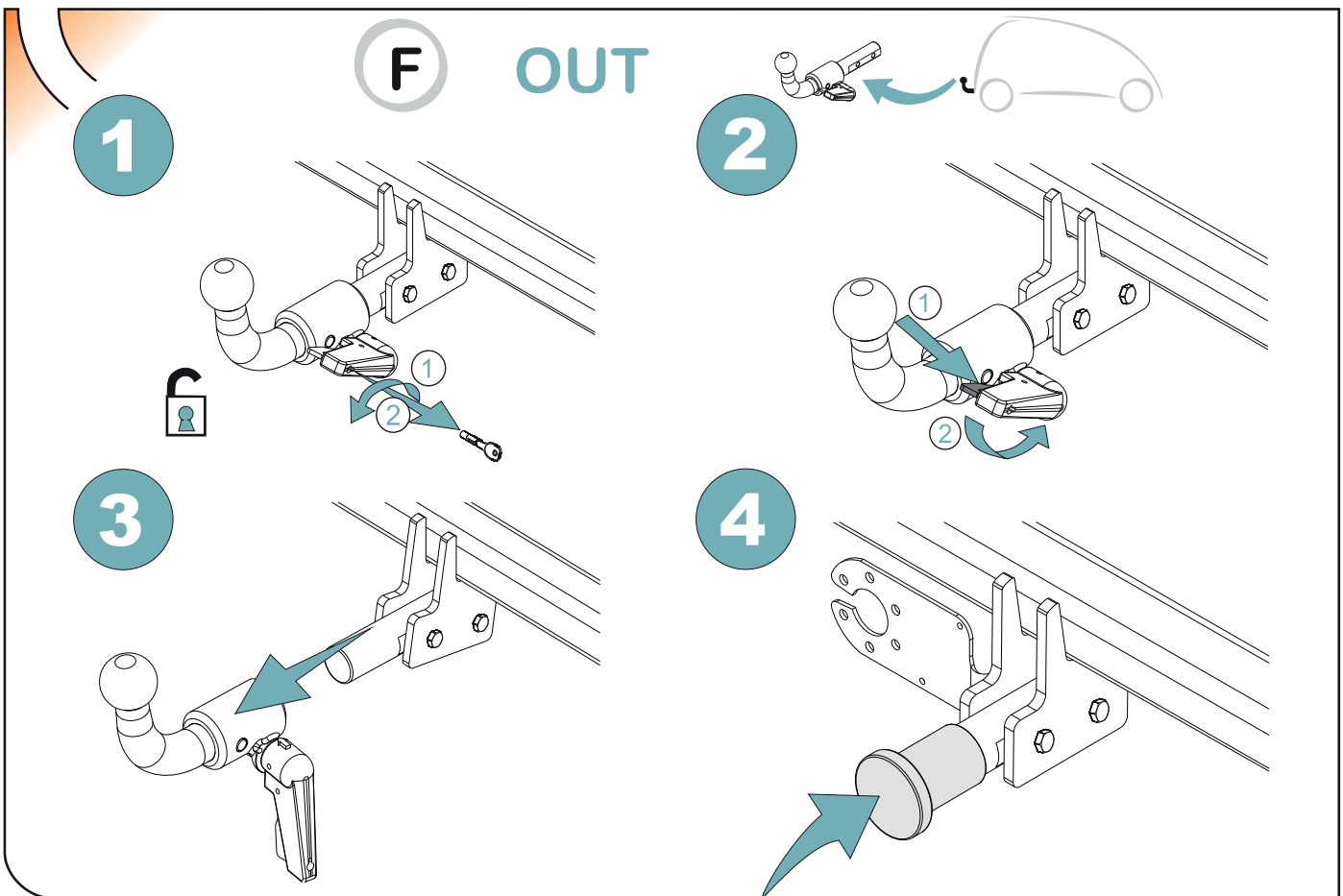
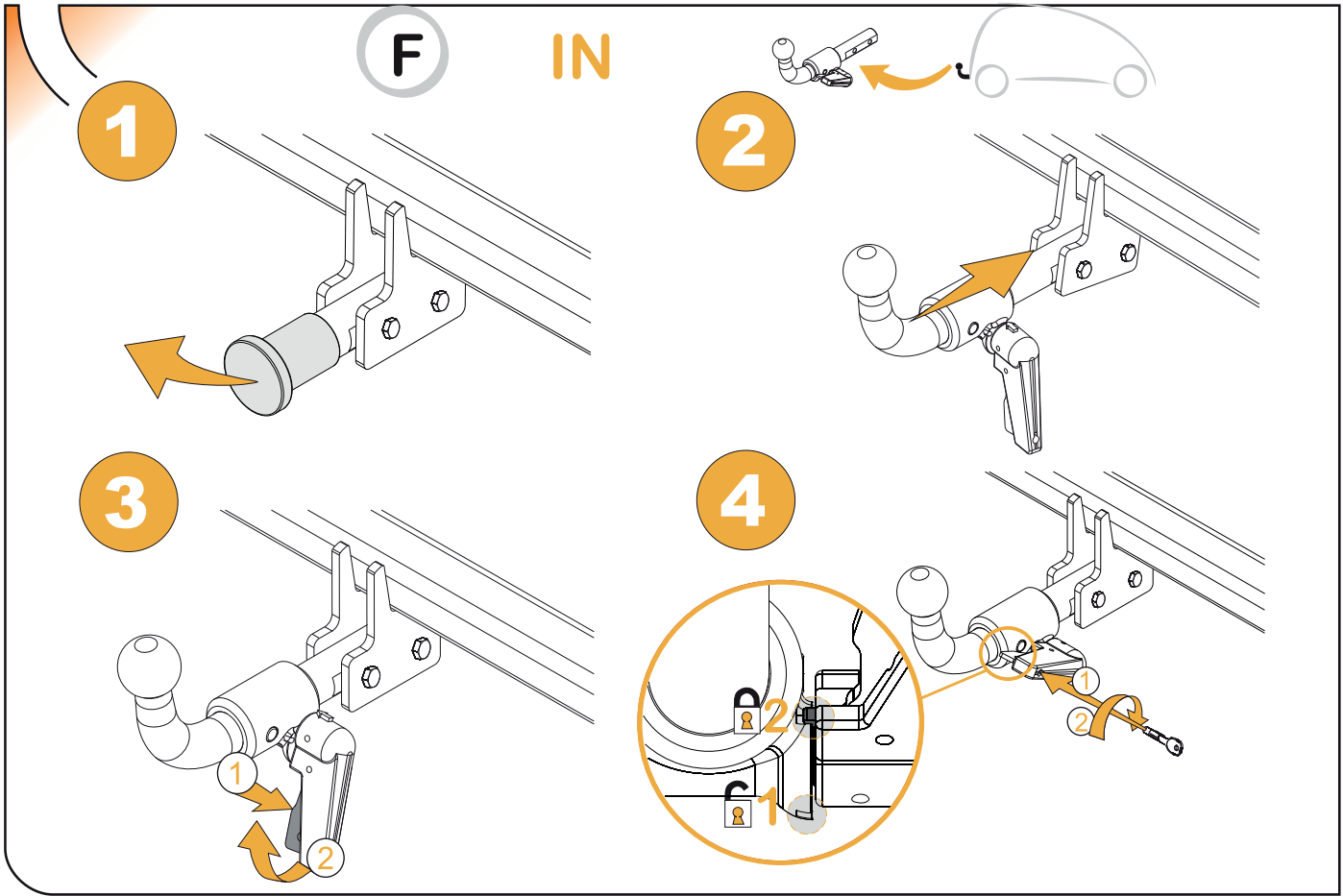

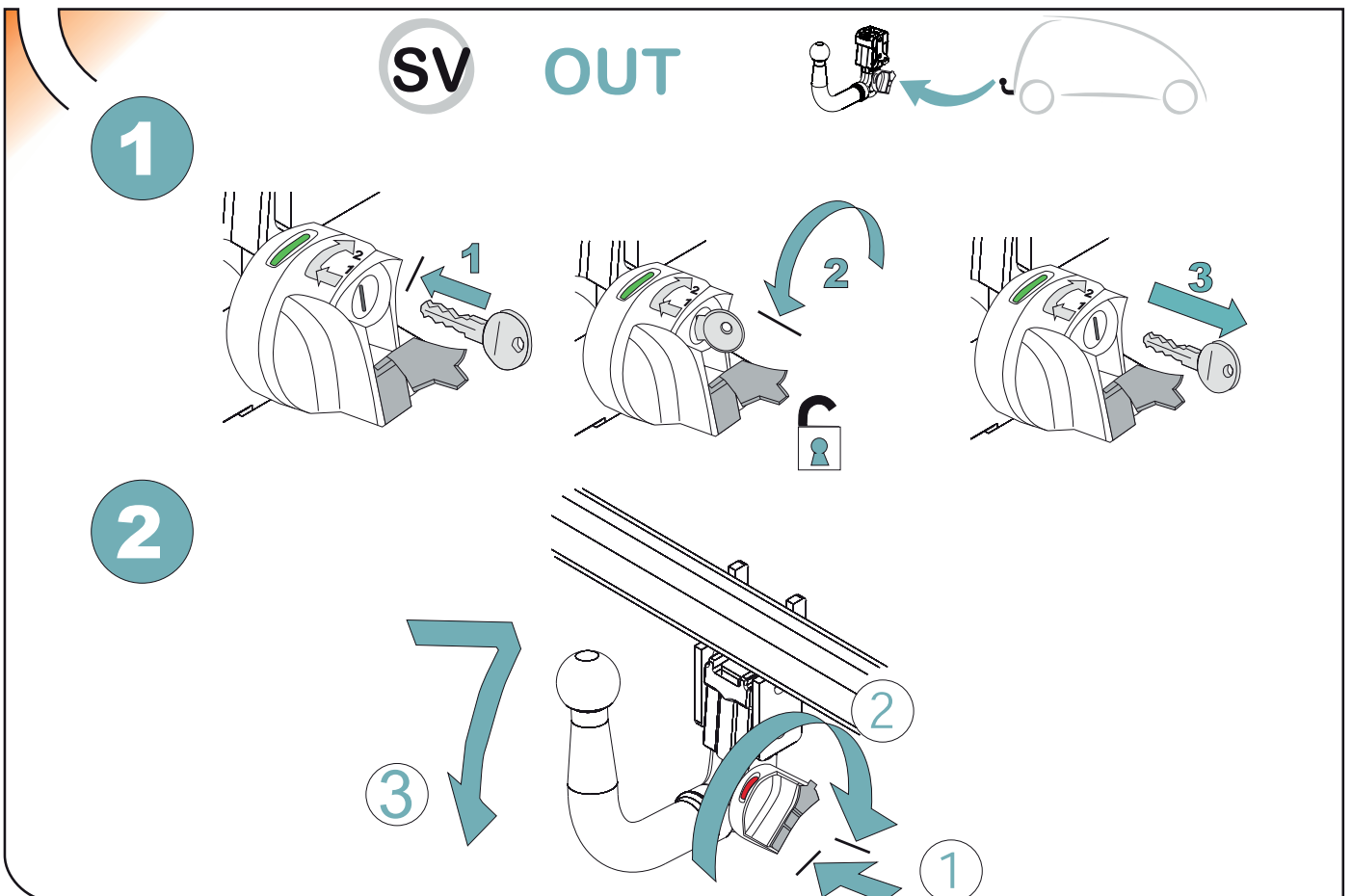
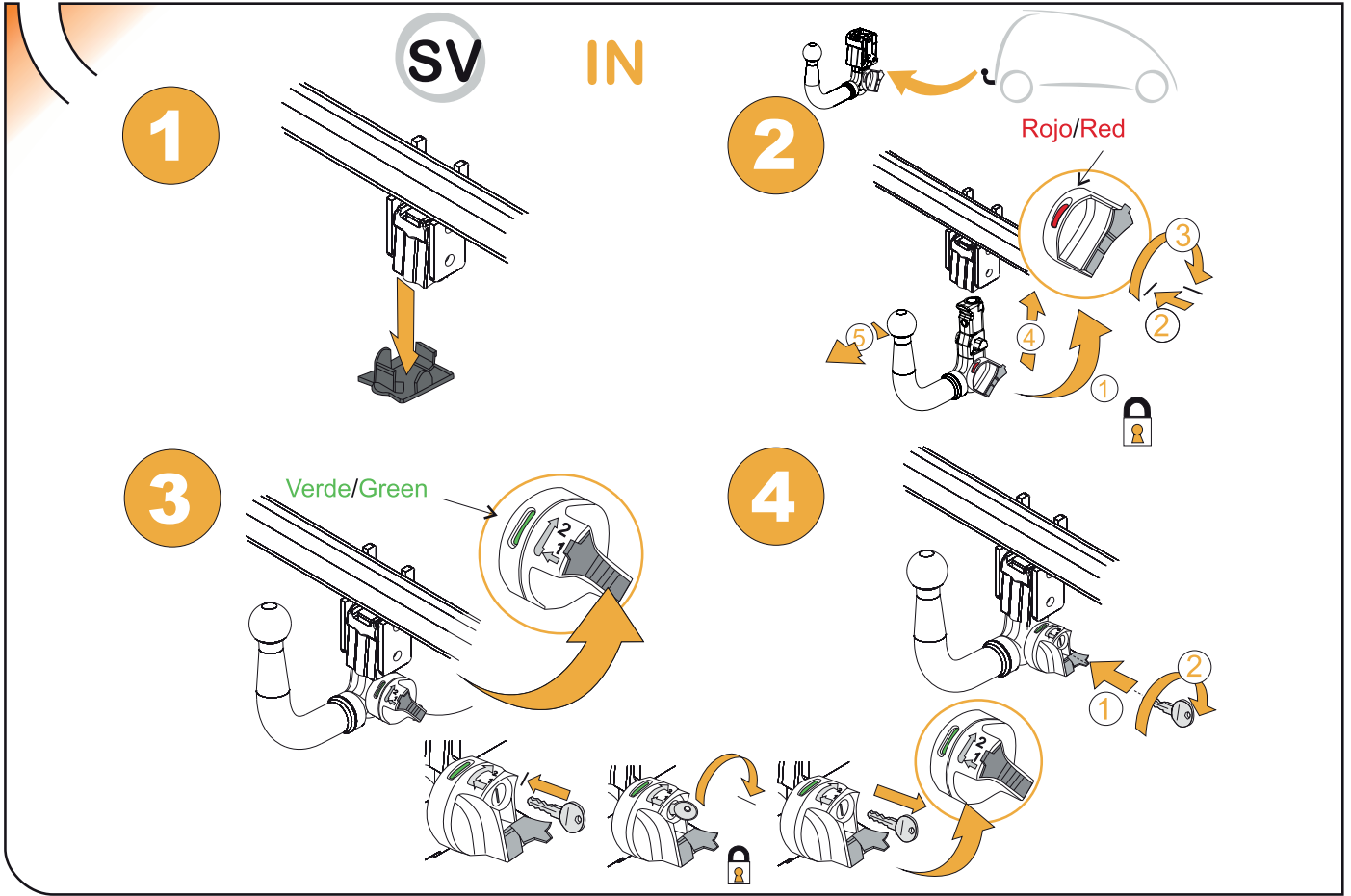

enganches

aragon

TowCar®



# ANEXO III

## CERTIFICADO DE TALLER

D. \_\_\_\_\_, expresamente autorizado por la empresa \_\_\_\_\_  
domiciliada en \_\_\_\_\_, teléfono \_\_\_\_\_, dedicada  
a la actividad de \_\_\_\_\_ n° de Registro Industrial \_\_\_\_\_ y n° de registro  
especial (1) \_\_\_\_\_.

### CERTIFICA

Que la mencionada empresa ha realizado la/s Reforma/s y asume la responsabilidad de la ejecución,  
sobre el vehículo marca....., tipo.....  
variante..... denominación comercial .....  
matrícula ..... y n° de bastidor ....., de acuerdo con:

- La normativa vigente en materia de reformas de vehículos.
- Las normas del fabricante del vehículo aplicables a la/s reforma/s llevadas a cabo en dicho vehículo.
- El proyecto descriptivo de la/s reforma/s, adjunto al expediente.

#### OBSERVACIONES: (2)

Tipificada/s con el código de reforma/s.....  
Reforma consiste en:

#### COLOCACION DE ENGANCHE HOMOLOGADO EUROPEO MARCA:

\_\_\_\_\_

n° de identificación / marca de homologación:

Type :

Garantizo que se cumple lo previsto en el artículo 6 del Reglamento General de vehículos y, en su caso, en el artículo 9 del R.D. 1457/1986, de 10 de enero, por el que se regula la actividad industrial en talleres de vehículos automóviles, de equipos y sus componentes, modificado por 455/2010 de 16 de abril.

....., a.....de.....de .....

Firma y sello:

(1) En el caso de que la reforma sea efectuada por el fabricante se indicará N/A.

(2) Se debe especificar en este apartado OBSERVACIONES, la identificación de los equipos o sistemas modificados.

ES

1

ANEXO III  
CERTIFICADO DE TALLER



2



3



IT

1

DICHIARAZIONE DI CORRETTO MONTAGGIO

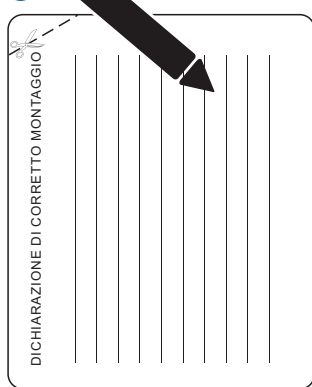

2

