

Renault Alaskan (2017-)
Nissan Navara [D40] (2005-)
Nissan NP300 Navara [D23] (2016-)
Mercedes-Benz Clase X (2017-)
-Con paragolpes
-With bumper
-Avec parachoc
-Mit stoßstange

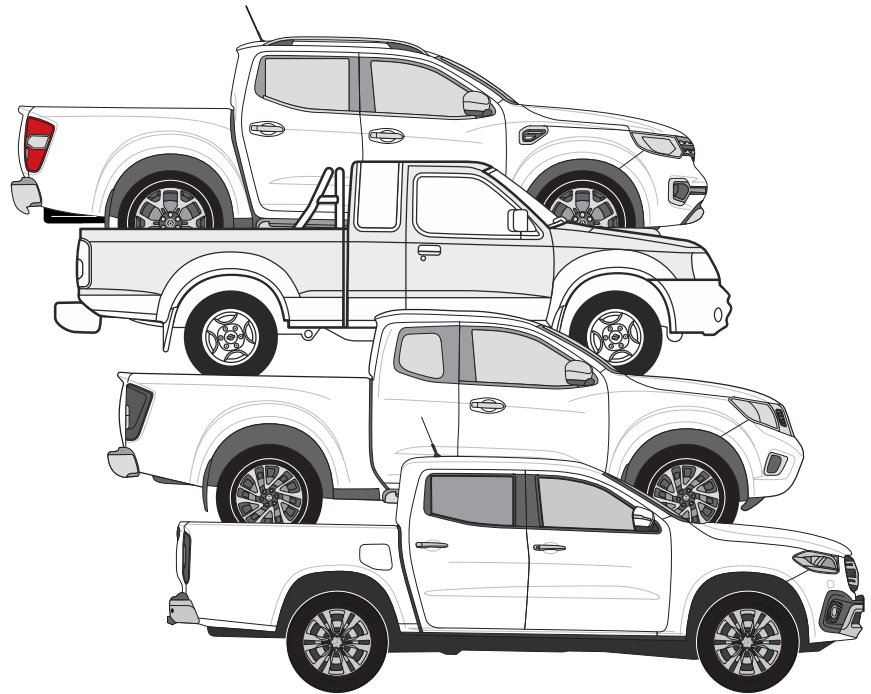

R55

Renault Alaskan (2017-)

Nissan Navara [D40] (2005-)

Nissan NP300 Navara [D23] (2016-)

Mercedes-Benz Clase X (2017-)

(Con paragolpes / With bumper / Avec parachoc / Mit stoßstange)

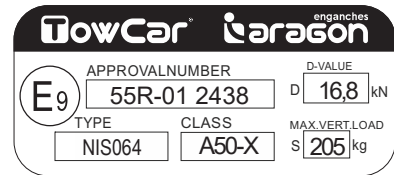
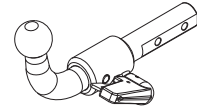
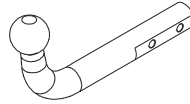

D= 16,8 kN



S= 205 kg

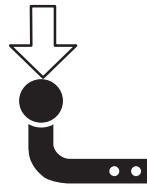

*T 3500 Kg



N/m	8,8	10,9	12,9
M6	10	15	18
M8	24	36	42
M10	51	75	87
M12	87	130	147
M14	138	198	231
M16	200	289	341

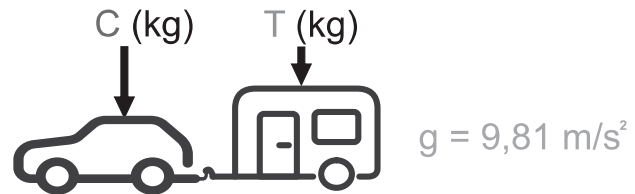

$$D \geq \frac{T \cdot C}{T + C} \cdot \frac{g}{1000} \text{ (kN)}$$







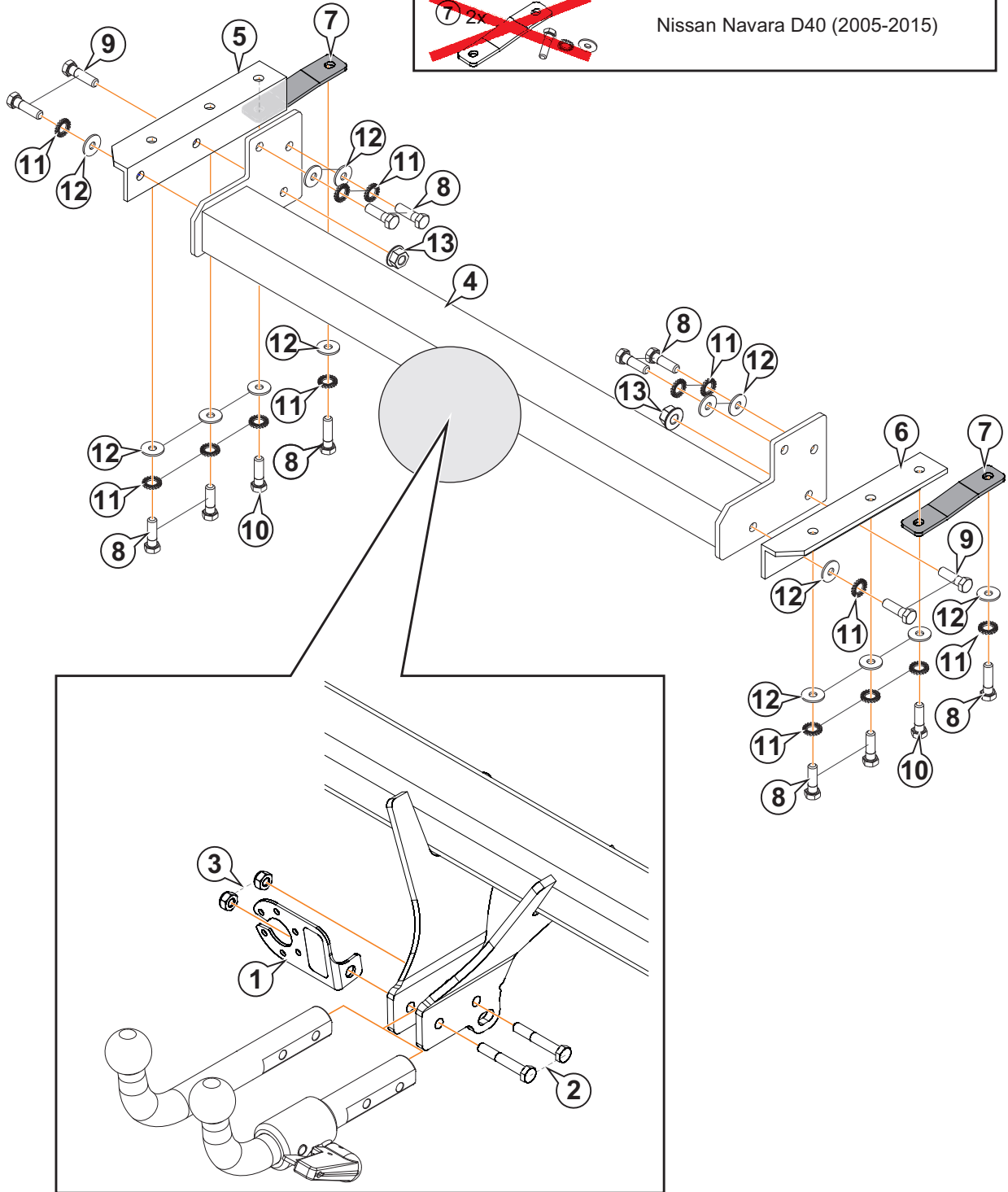

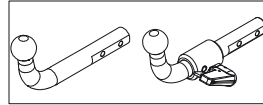



$$T \leq \frac{C \cdot D \cdot 1000}{(C \cdot g) - (1000 \cdot D)} \text{ (kg)}$$

*El MMR (T) puede variar dependiendo del vehículo.

<p>7 2x</p>	<p>Renault Alaskan / Nissan NP 300 / Navara D23 (2016-) / Mercedes-Benz Classe X (2017-)</p>
<p>7 2x</p>	<p>Nissan Navara D40 (2005-2015)</p>





1		AEV0005	1	
2		M10x65 DIN 931(8.8)	2	
3		M10 DIN 980	2	
4		C4131BX60	1	
5		C4131BC24	1	
6		C4131BC23	1	
7		C4404CA21 (NP300 Navara/ Clase X / Alaskan)	2	
8		M12x1,25x30 DIN 961 (8.8)	10	
9		M12x40 DIN 933	4	
10		M12x1,25x40 DIN 961 (8.8)	2	
11		Ø12 DIN 128A	14	
12		Ø12 DIN 9021	14	
13		M12 DIN 6923	2	

1

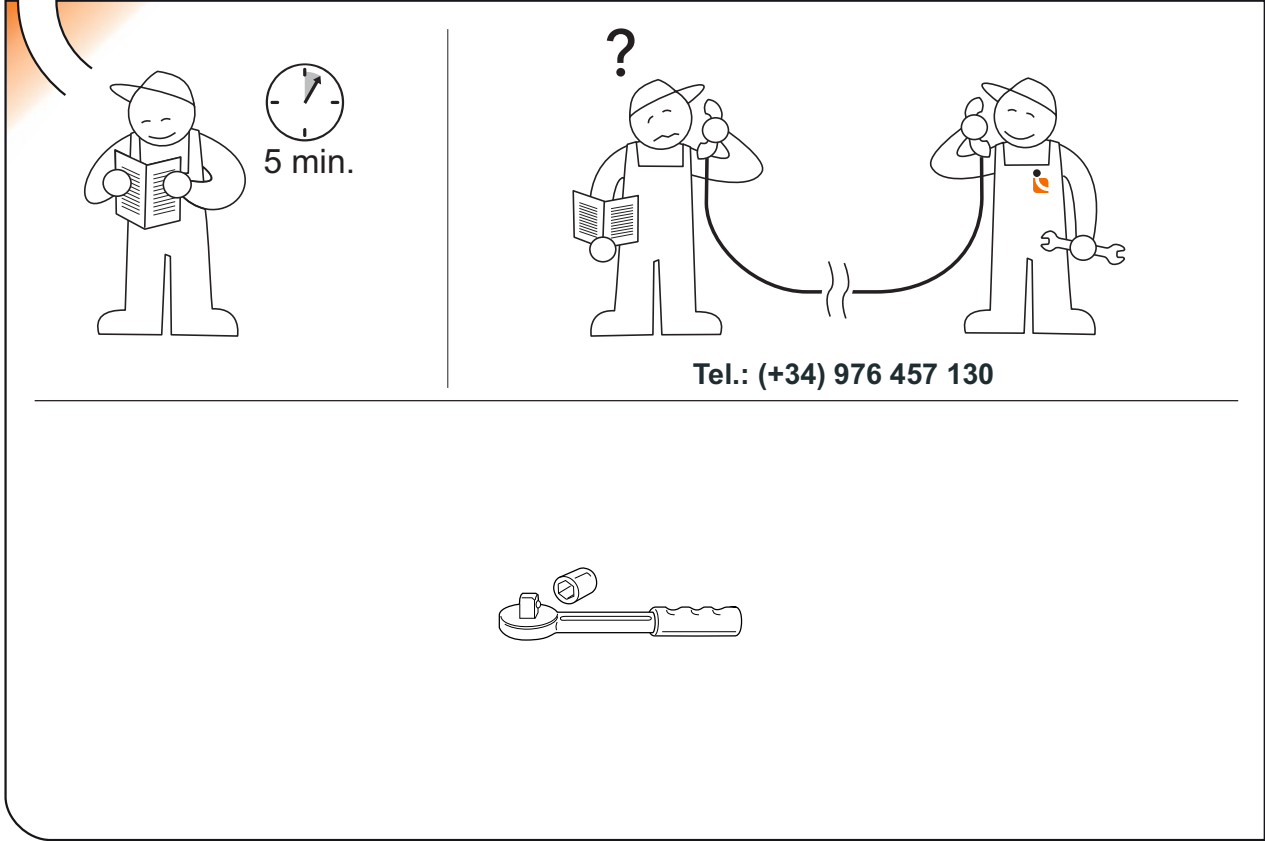

5 min.

?

Tel.: (+34) 976 457 130

The illustration shows a worker on the left reading a manual next to a clock icon labeled '5 min.'. On the right, a worker with a question mark above their head is talking on a mobile phone, which is connected by a cord to another worker on the right who is holding a wrench. Below this scene is a detailed drawing of a long-handled bolt with a nut and a washer.

2

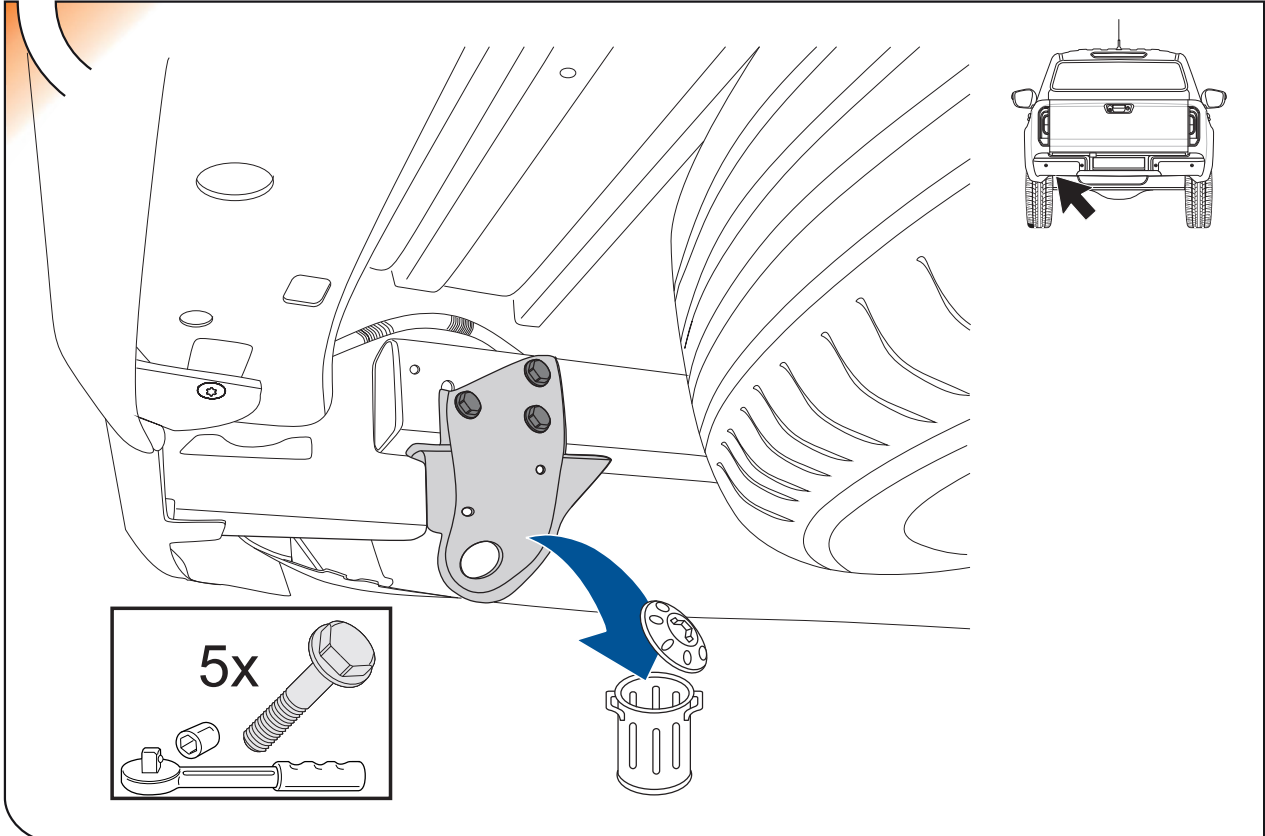

5x

The diagram shows a close-up of a car's rear bumper assembly with a blue arrow pointing to a disposal bin. A small inset shows a car from the rear with an arrow pointing to the bumper area. A box in the bottom left corner shows five bolts with the text '5x'. The disposal bin is shown with a lid and a trash can icon.

3

NP 300 Navara (2016-)
Clase X (2017-)
Alaskan (2017-)

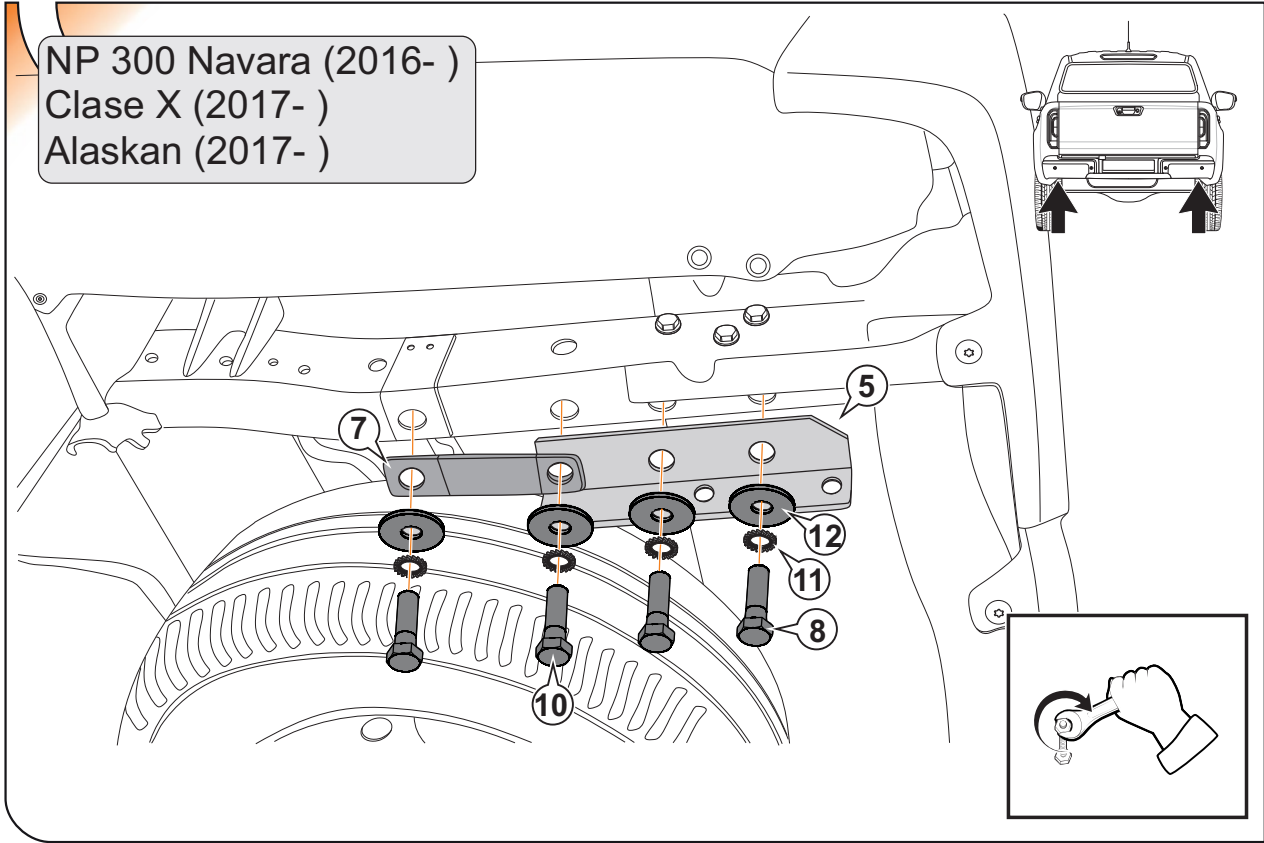

4

Navara (2005-)

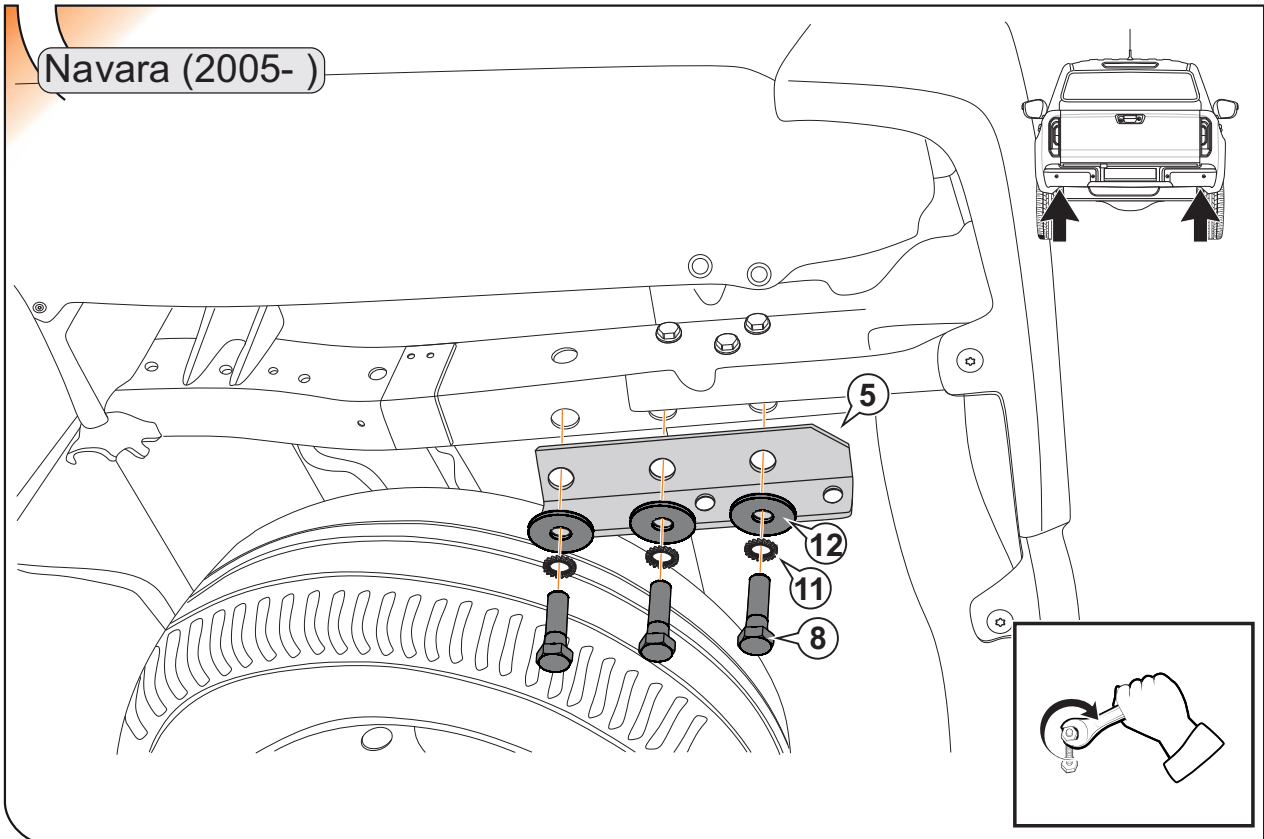

5

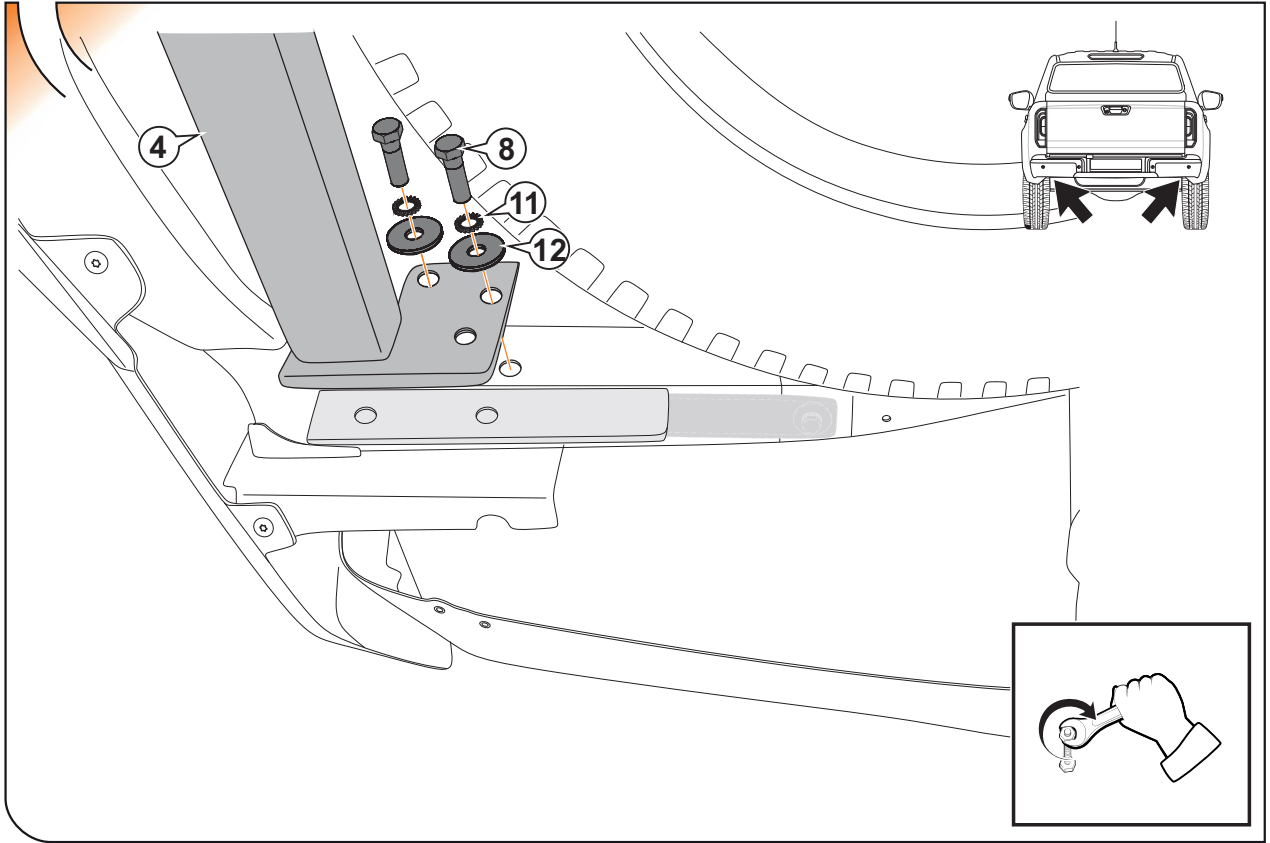

6

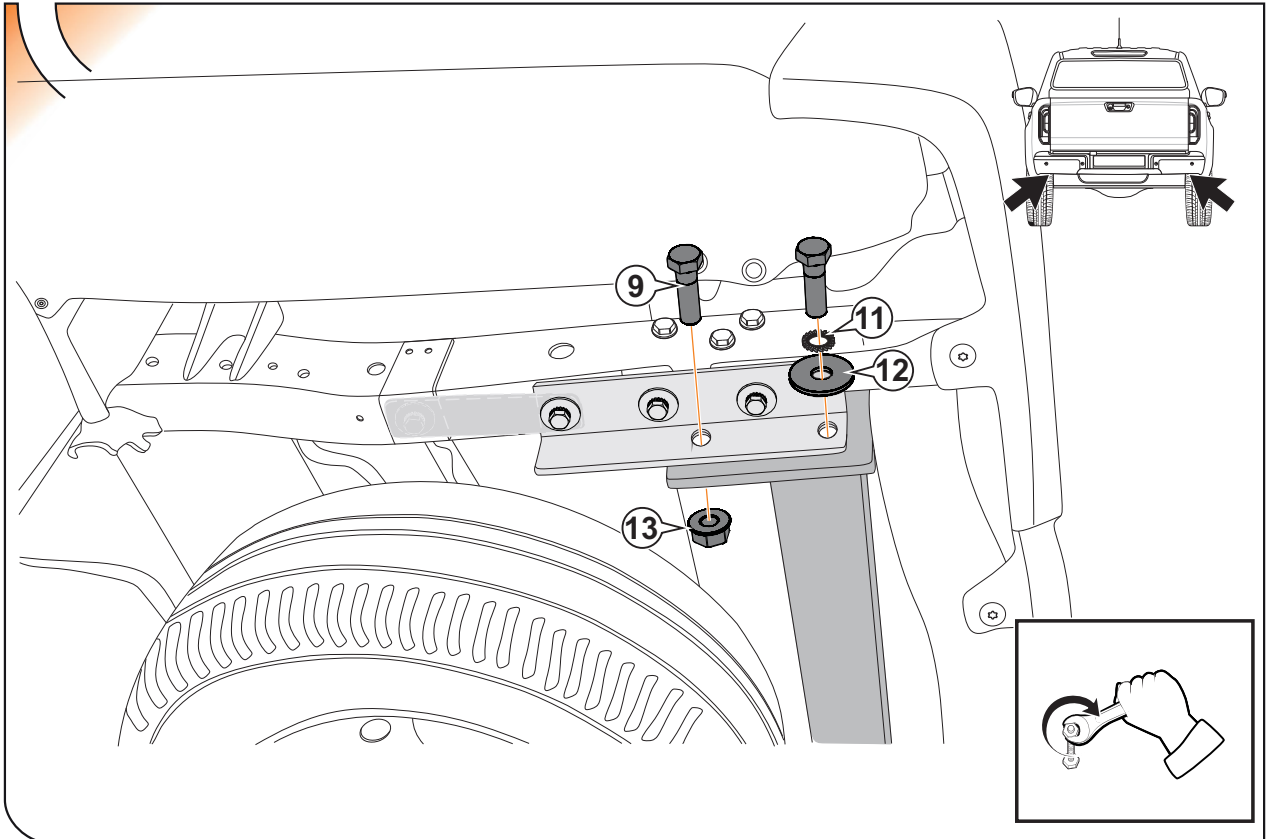

7

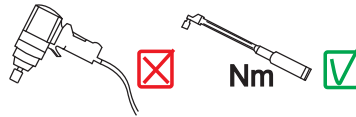

N/m	8,8	10,9	12,9
M6	10	15	18
M8	24	36	42
M10	51	75	87
M12	87	130	147
M14	138	198	231
M16	200	289	341

8

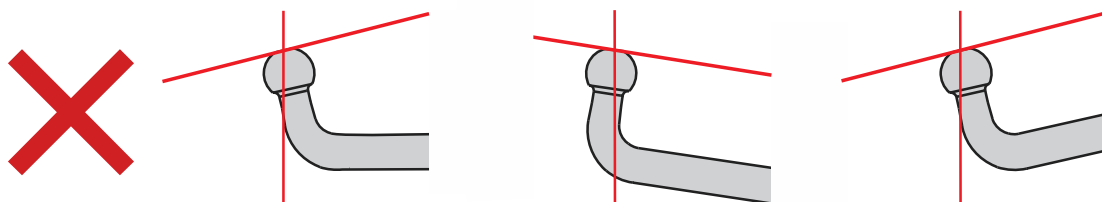
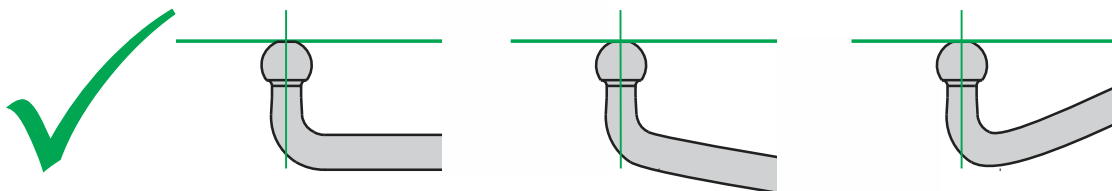

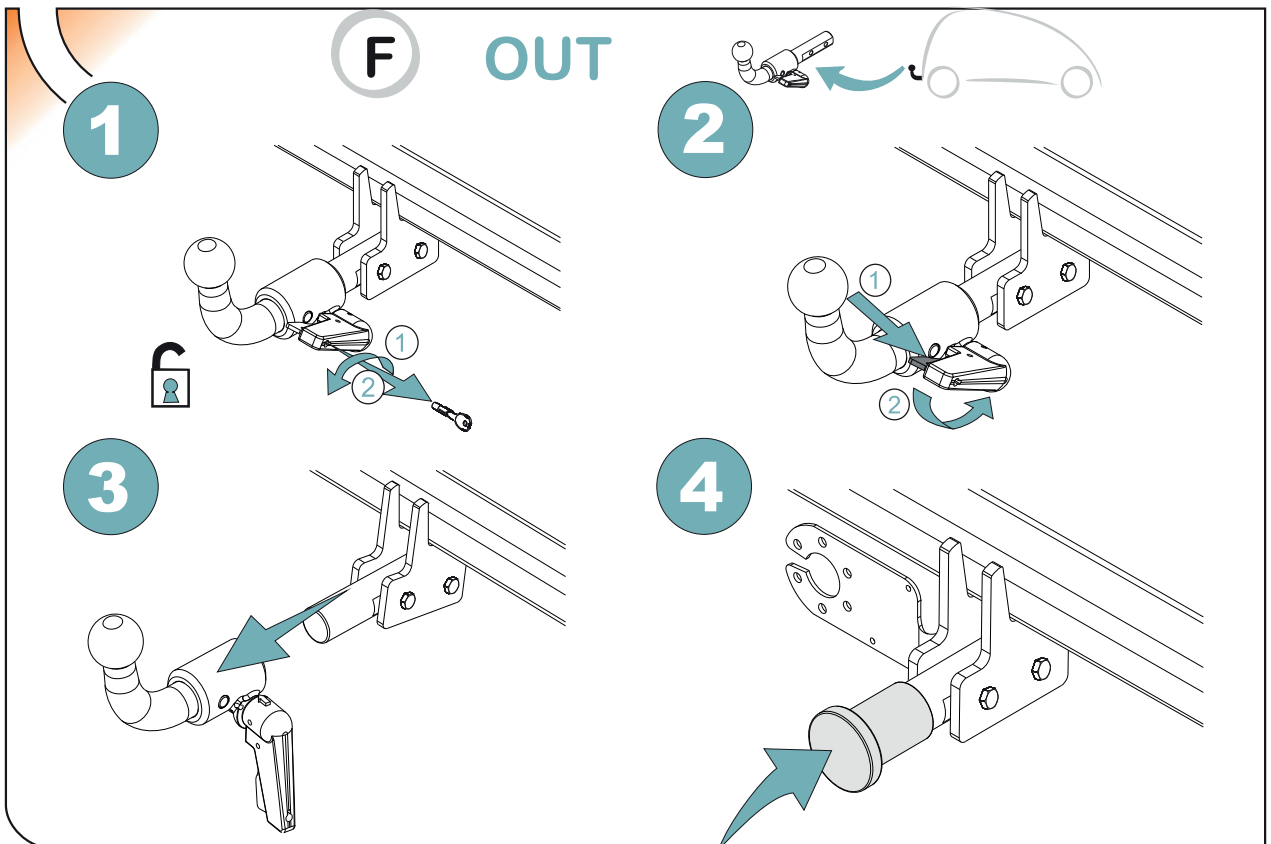
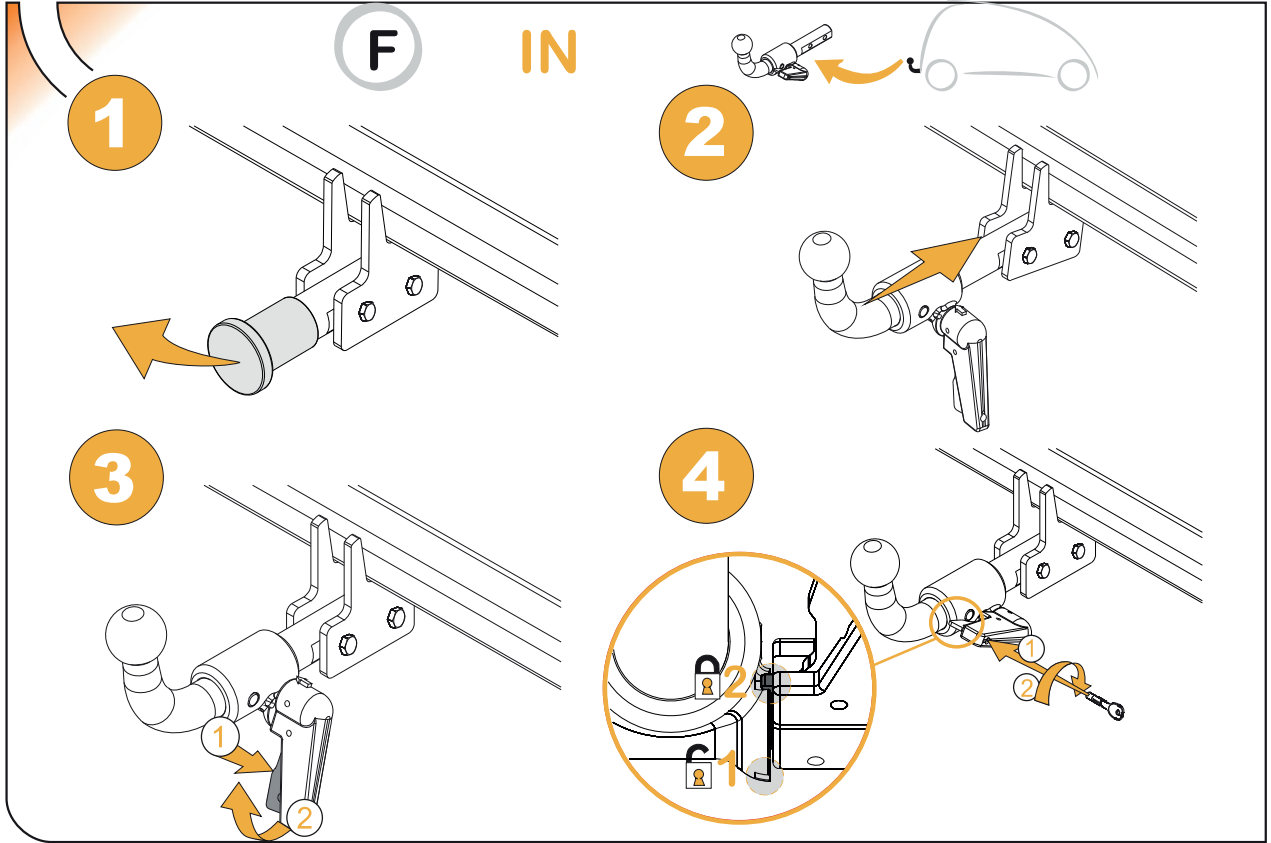

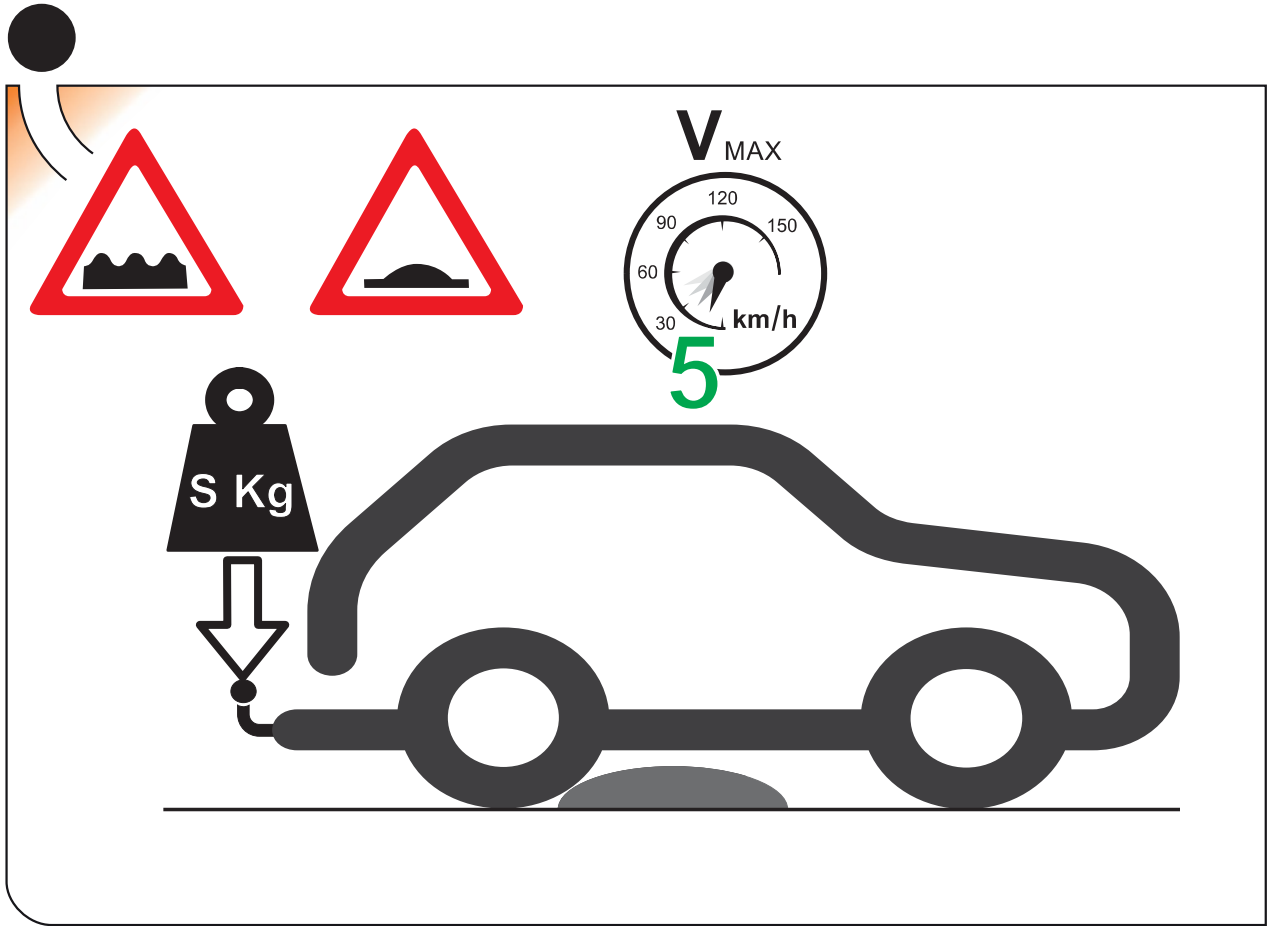



ANEXO III

CERTIFICADO DE TALLER

D. _____, expresamente autorizado por la empresa _____
domiciliada en _____, teléfono _____, dedicada
a la actividad de _____ n° de Registro Industrial _____ y n° de registro
especial (1) _____.

CERTIFICA

Que la mencionada empresa ha realizado la/s Reforma/s y asume la responsabilidad de la ejecución,
sobre el vehículo marca....., tipo.....
variante..... denominación comercial
matrícula y n° de bastidor, de acuerdo con:

- La normativa vigente en materia de reformas de vehículos.
- Las normas del fabricante del vehículo aplicables a la/s reforma/s llevadas a cabo en dicho vehículo.
- El proyecto descriptivo de la/s reforma/s, adjunto al expediente.

OBSERVACIONES: (2)

Tipificada/s con el código de reforma/s.....
Reforma consiste en:

COLOCACION DE ENGANCHE HOMOLOGADO EUROPEO MARCA:

n° de identificación / marca de homologación:

Type :

Garantizo que se cumple lo previsto en el artículo 6 del Reglamento General de vehículos y, en su caso, en el artículo 9 del R.D. 1457/1986, de 10 de enero, por el que se regula la actividad industrial en talleres de vehículos automóviles, de equipos y sus componentes, modificado por 455/2010 de 16 de abril.

....., a.....de.....de

Firma y sello:

(1) En el caso de que la reforma sea efectuada por el fabricante se indicará N/A.

(2) Se debe especificar en este apartado OBSERVACIONES, la identificación de los equipos o sistemas modificados.

ES

1



2



3



IT

1

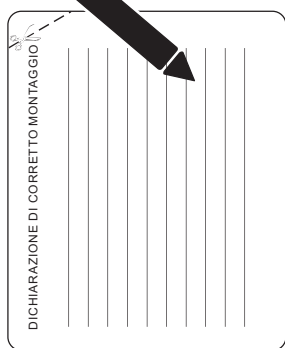

2

